

ca:3elli 4U



cazzelli 4U



Lavorare la pietra non è un gesto insignificante. Per la sua antichità, per la ritualità dei gesti, conserva ancora oggi il senso di uno scontro titanico. Prima di tutto c'è il blocco. Blocco che comprende già in sé la forma che abbiamo in mente di ricavare. Blocco che è già finito di suo. La luce è un'aggiunta che illumina la facciata di una villa di un antico comune, di un parco pubblico dove vi sono bambini, giovani, anziani che con le loro voci fanno da contorno e danno vita a questi oggetti che, spenti, sono parte integrante del paesaggio.

Nella nostra visione l'illuminazione attuale deve essere fusione di classico e contemporaneo.

Le lampade Ca' Belli a parete, per esempio, devono inserirsi come reperti rivisitati in chiave di design, essere oggetti antichi adatti ad abbellire case contemporanee.

La storia del Montefeltro e l'armonia dei luoghi influiscono sull'Azienda e sul lavoro dei giovani Collaboratori che individuano di continuo nuove lavorazioni della pietra naturale, resistente al tempo ed alle intemperie, in modo da farla diventare materiale plasmabile che fa passare la luce.

Gianni Lisi





## Montefeltro

---

Working with stone is a gesture full of significance, the titanic struggle between great forces lives on through the antique rituals of stone workmanship. First comes the block. Block that bears within the shapes that we have mentally designed and that is already a finished item on its own.

Light is an addition illuminating the facades of the old villas and country houses of the Montefeltro, or of a park alive with the voices of children, grandparents, young people, voices that bring these objects to light- objects that turned off- become an integral part of the countryside.

In our interpretation of present day illumination, the fusion between classic and contemporary is a must. An example for all are our sconces, introduced as redesigned ancient finds, suitable to embellish and valorize contemporary environments.

The History and countryside of the Montefeltro Region have a deep influence on the people in Ca' Belli who are always looking for new ways to work natural stone, to maintain its durability and resistance to harsh conditions and yet obtain a malleable material that lets light shine through.

*Gianni Lisi*

indice - index ▶

# indice tipologico - typological index

## collezioni - collections

damasco .....	32
inari .....	40
lemni .....	46
micene .....	24
parete - wall	
afra ....	167
afra IP55 ....	167
block ....	146
block 400 ....	147
block maxi ....	147
block mini ....	146
block orizzontale ....	149
block plus ....	148
block verticale ....	149
cody .....	160
cody JM .....	160
cody essential ....	162
cody lite ....	161
cody moma ....	161
cody plus .....	163

dada .....	85
dada maxi .....	85
elettra .....	78
little .....	59
little maxi .....	59
metro cubo .....	98
metro cubo IP55 .....	98
metro quadro .....	97
metro quadro IP55 .....	97
ombra ....	131
pedro .....	89
piccola sissi .....	54
pop ....	135
pop maxi ....	135
quadra parete 110 .....	68
quadra parete 250 .....	68
quadra parete 400 .....	69
repetita .....	79
sissi .....	55
yoyo ....	172
zero sissi .....	54

## soffitto - ceiling

metro 130 .....	99
metro 25 .....	99
quadra soffitto 160 .....	70
quadra soffitto 290 .....	70
quadra soffitto 420 .....	71
yoyo up ....	173

## terra - floor

gigia 30 ....	106
gigia 60 ....	106
gigia 90 ....	107
gigia 120 ....	107
lucciolo ....	111
lucciolo 130 ....	111
mezzanotte 130 ....	121
mezzanotte 170 ....	122
mezzanotte 300 ....	123
piccolo sole ....	179
sole di mezzanotte ....	179

## alfabetico - alphabetical

afra ...	167
afra IP55 ...	167
block ...	146
block 400 ....	147
block maxi ....	147
block mini .....	146
block orizzontale .....	149
block plus .....	148
block verticale .....	149
cody .....	160
cody JM .....	160
cody essential .....	162
cody lite .....	161
cody moma .....	161
cody plus .....	163
dada .....	85
dada maxi .....	85
damasco .....	32
elettra .....	78
gigia 30 .....	106
gigia 60 .....	106
gigia 90 .....	107

gigia 120 .....	107
inari .....	40
lemni .....	46
little .....	59
little maxi .....	59
lucciolo .....	111
lucciolo 130 .....	111
metro 130 .....	99
metro 25 .....	99
metro cubo .....	98
metro cubo IP55 .....	98
metro quadro .....	97
metro quadro IP55 .....	97
mezzanotte 130 .....	121
mezzanotte 170 .....	122
mezzanotte 300 .....	123
micene .....	24
ombra .....	131
pedro .....	89
piccola sissi .....	54
piccolo sole ....	179

pop .....	135
pop maxi .....	135
quadra parete 110 .....	68
quadra parete 250 .....	68
quadra parete 400 .....	69
quadra soffitto 160 .....	70
quadra soffitto 290 .....	70
quadra soffitto 420 .....	71
repetita .....	79
sissi .....	55
sole di mezzanotte .....	179
yoyo .....	172
yoyo up .....	173
zero sissi .....	54





photo: Olga Di Maso





La nostra scelta premiante è la materia prima, per le sue caratteristiche intrinseche di età, preziosità, durata.

Ca' Belli utilizza su base routinaria diverse pietre: ardesia, lavica, leccese, marmo, pietra serena ed ora anche alabastro.

La selezione dei materiali e la lavorazione artigianale nobilitano il blocco di pietra facendolo diventare espressione della creatività e del design dell'uomo.

Natural materials with their intrinsic qualities of age, preciousness and durability epitomize Ca'Belli's winning choice; different typologies of natural stone, like Slate, Lava and Serena stone, marble and now alabaster now.

The attentive selection of materials combined with the craftsmanship of master stone cutters enable the stone to transform into an expression of man's creativity.







## Pietra leccese

È una roccia calcarea dolce nelle lavorazioni, caratterizzata dalla presenza di fossili - soprattutto planctonici - che a volte sono conservati quasi integralmente.

La texture della leccese - nei suoi aspetti di natura grafica e compositiva - dà sensazioni tattili e visive che sono chiamate a rappresentare immagini a tratti opulente a tratti minimali riconducibili - da un punto di vista culturale - a tante idee diverse.

La pietra leccese si può considerare il simbolo unificante della cultura e della storia millenaria del sud-orientale dell'Italia: il Salento. È proprio questa pietra dorata come il sole, facile da modellare, capace di sfidare i secoli che può far da guida ai fasti, alle fantasie ed alle decorazioni dell'arte scultorea salentina. Ha origini antichissime, risale al Miocene, periodo dell'era del Terziario durato da 23 a 17 milioni di anni fa.

## Lecce stone

Lecce stone is a limestone characterized by the presence of fossils, mostly plankton species - sometimes perfectly preserved.

The texture of Lecce stone - for its graphics and composition - yields tactile and visual sensations, eloquent images that can be opulent or have minimal traits instead, but are all traceable from a cultural point of view. Lecce stone can be considered the unifying symbol of the thousand-year-old culture and History of Salento, a region of South-Eastern Italy. This sun-gold stone, malleable, and yet able to withstand the passing of centuries, is the motif underlying the pomp, the fantasies and the decorations of The Sculpture Art of this region. Its antique origins dates back to the Miocene, a period of the Cretaceous, Tertiary era that lasted from 23 to 17 million years ago.



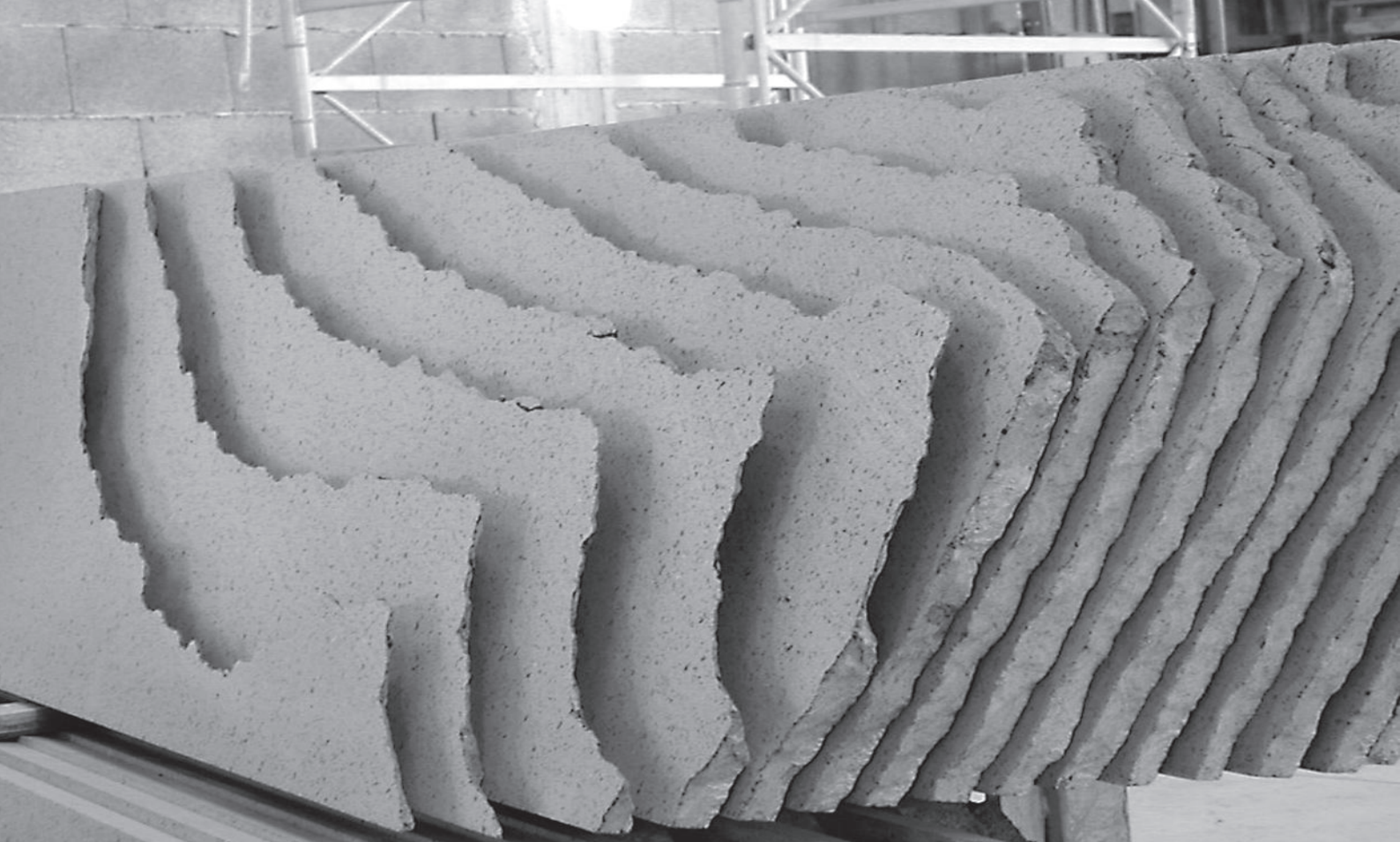

## Pigmentazione

Il mondo della pietra è il mondo della materia per eccellenza. Ogni professionista che apprezza la superficie, il colore e le cromie delle pietre nasconde un appassionato che ama questi materiali. Il mercato offre una grande varietà di scelte, ma ci sono richieste che non sempre trovano risposta. Si può avere il materiale della leccese con una gamma di colori diversi per il modello prescelto? Bisognerebbe inventarsi una pietra nuova. Ca' Belli - grazie alla conoscenza approfondita e intima della materia - ha accolto le richieste dei propri Clienti creando una nuova natura della leccese che ora si presenta con una gamma di colorazioni naturali, eseguite rigorosamente a mano, con pigmenti selezionati. Il risultato è straordinario e la richiesta ha premiato questa novità facendola entrare di diritto tra i nuovi materiali proposti.



rosso mattone / brick red

Caldo corposo, il rosso è un colore che rende le lampade Ca' Belli ideali nei contesti dei centri storici.

*Warm earthy hue, red is a colour that makes the Ca' Belli lamps ideal in old town environments.*



marrone / brown

Una colorazione che si sposa in ogni contesto raggiunge la perfezione legandosi intimamente con la pietra leccese.

*A colour that is a perfect match in every environment and reaches perfection through a deep binding to the very heart of Lecce Stone.*



antracite / anthracite

Adulto, contemporaneo, un colore dal carattere maturo che esalta la personalità minimale delle nostre lampade.

*Adult, contemporary, a color with a mature character enhancing the minimalist personality of our lamps.*



## Pigmentation

The world of Stone is the world of materials par excellence. Every architect or designer that appreciates the tactile and chromatic aspects of stone is passionate about Materials. Markets offer a great variety of choices but not every request is satisfied. A frequent request from our client is: "I like this model, is it possible to have it with the texture of Lecce stone but in another color?" Ca 'Belli has put its expertise and its deep knowledge of the Material to satisfy such requests giving Lecce stone a new nature. Clients can now choose among different natural colors, obtained with a manual process using only natural pigments. The result is outstanding and the many requests testify the appeal of this novelty which is now available for all the articles proposed in Lecce stone.





**Pietra naturale** L'utilizzo di un materiale naturale come la pietra aiuta a riflettere sul territorio, sulla sua evoluzione, sul suo avvenire, sulla fragilità dei suoi equilibri ma può anche essere elemento di identificazione per la popolazione. L'iter della lavorazione della pietra naturale colma una lacuna della nostra società: la conoscenza di processi produttivi dimenticati. La *via della pietra* permette di ritrovare questo rapporto fisico con i prodotti della natura, con la loro trasformazione e con l'utilizzo che l'uomo ne fa. Forse utopistica, l'ambizione della nostra *via della pietra* è quella di permettere agli Abitanti della Terra di dotarsi di una rinnovata coscienza dello sviluppo sostenibile. Gli altri aspetti didattici, le correlate occasioni di acquisire nuove conoscenze del territorio circostante sono distribuiti in punti specifici del percorso. I momenti di apprendimento sono indipendenti tra loro e - come la stessa via della pietra - non seguono un ordine prestabilito.

**Natural Stone** The use of a natural material such as stone makes us think about territory, its evolution, its future, the fragility of its equilibrium but, for the population of that territory, stones can become an identification sign. The path traced by the many hands working stone, from its extraction to the final use, fulfils a gap of our society; an antique wisdom that is kept alive through the use of almost forgotten workmanship. Stone Architecture enables us to recuperate a physical relationship with nature's products, with their transformation and with the use that man makes of it. Mere utopia, maybe, but the aim underlying our Stone Architecture is to allow Mother Earth's inhabitants to develop a renewed awareness of sustainable growth. Other learning experiences and opportunities arise naturally all along this stone route.

**Ductal®** Ductal® è una tecnologia innovativa che copre una famiglia di calcestruzzi ad alte prestazioni con caratteristiche eccezionali tanto meccaniche che di resistenza all'abrasione, alle aggressioni chimiche o alle intemperie come gelo-disgelo, acqua di mare, ecc.

**Ductal®** Ductal® is obtained with an innovative technology and consists of a range of high performance concrete with exceptional mechanical characteristics, it also features abrasion, and environmental resistance -chemical and harsh weather environments, for example freeze and thaw, salt water, etc...

Origine / Origin > roccia metamorfica sedimentaria / *metamorphic sedimentary rock*  
Finitura / Finish > levigata, a spacco di cava / *smooth, or natural split*  
Provenienza / From > Liguria, Italia / *Liguria, Italy*

Origine / Origin > roccia sedimentaria arenaria / *sedimentary sandstone rock*  
Finitura / Finish > grana fine e compatta, resistente / *fine-grained and compact*  
Provenienza / From > Toscana, Italia / *Tuscany, Italy*

Origine / Origin > sedimentazione colate laviche / *lava flow sedimentation*  
Finitura / Finish > levigata / *smooth*  
Provenienza / From > Sicilia, Italia / *Sicily, Italy*

Origine / Origin > calcarea, sedimentazione marina / *sedimentary marine limestone*  
Finitura / Finish > grana fine, compatta, irregolare / *fine-grained, compact, irregular*  
Provenienza / From > Puglia, Italia / *Apulia, Italy*

Origine / Origin > calcarea sedimentaria / *sedimentary limestone*  
Finitura / Finish > grana grossolana / *coarse-grained*  
Provenienza / From > Italia e Turchia / *Italy and Turkey*

Origine / Origin > minerale gessoso / *chalky mineral*  
Finitura / Finish > levigata / *smooth*  
Provenienza / From > Toscana, Italia / *Tuscany, Italy*

Origine / Origin > marmo con venature bianche / *marble with white calcite veins*  
Finitura / Finish > levigata / *smooth and shiny*  
Provenienza / From > Toscana, Italia / *Tuscany, Italy*

Origine / Origin > marmo con venature bianche / *marble with white calcite veins*  
Finitura / Finish > levigata / *smooth and shiny*  
Provenienza / From > Toscana, Italia / *Tuscany, Italy*

*Ardesia a spacco / Natural cleft Stone*

*Ardesia levigata / Slate Stone*

*Serena / Serena Stone*

*Basaltina / Basalt*

*Lavica / Lava Stone*

*Leccese / Lecce Stone*

*Rosso mattone  
Brick Red*

*Antracite  
Anthracite*

*Marrone  
Brown*

*Crema / Crema*

*Alabastro / Alabaster*

*Rosso King / Rosso King*

*Grey Stone / Grey Stone*

*Ductal® / Ductal®*

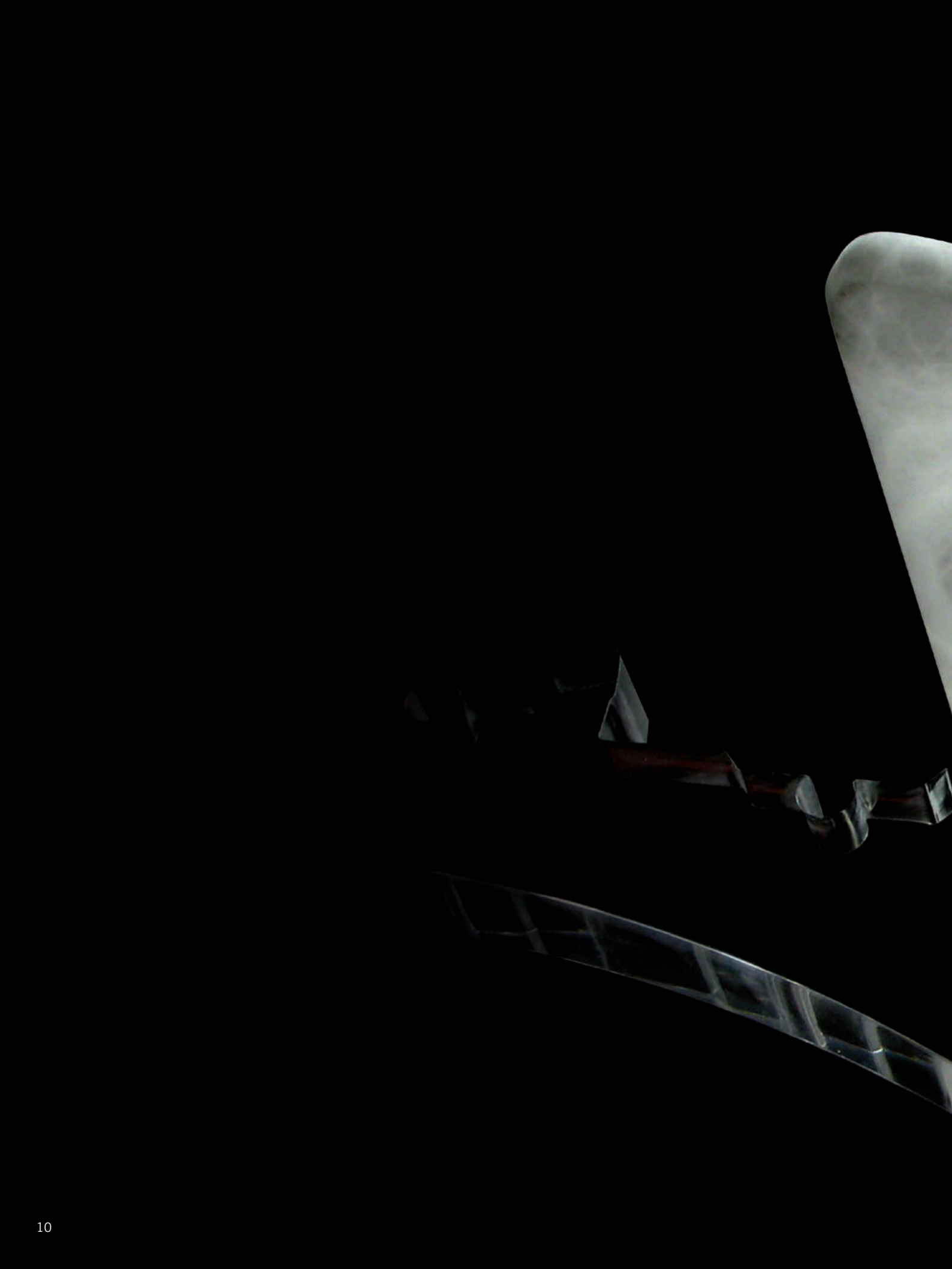



# micene

Una scultura di luce la lampada creata da Paolo Lucidi e Luca Pevere in esclusiva per la ditta Ca' Belli. La proposta creativa unisce in modo innovativo la forza dell'acciaio, la trasparenza del vetro e il pregio dell'alabastro bianco per creare quattro "sculture" da terra, da parete, da tavolo e da sospensione.

Anche Micene, come tutte le altre proposte Ca' Belli, rappresenta la creazione di un unicum intriso del valore artistico e storico del Made in Italy.

---

*Micene, a sculpture of light created by Paolo Lucidi and Luca Pevere exclusively for Ca' Belli. The creative concept is an innovative combination of; the strength of steel, the transparency of glass and the preciousness of white alabaster. The result, four sculptures, floor, wall, table and suspension.*

*Micene and the entire proposal originating in Ca' Belli represents a unicum imbued of the artistic and historical values of our Made in Italy.*





## Alabastro

L'Alabastro è un a pietra preziosa e Ca'Belli ha scelto di usarla come materiale destinato solo ad una produzione di eccellenza. Trasparente e leggera, è la pietra più creativa che madre natura ha donato agli uomini per le creazioni di luce più esclusive.

## Alabaster

Alabaster is a precious stone and Ca'Belli has chosen to use it only for its most exclusive production. Sheer and seemingly weightless, it is the most creative stone that Mother Nature has given mankind for its most exclusive creations of light.





Connubio tra il materiale - offerto dalla natura - comune a tutti gli uomini - che rende ogni oggetto nato in Ca' Belli un unicum.

Quindi la creatività della natura unita a quella del designer per fare vibrare i sensi, le radici primordiali e culturali che sono nel nostro Dna.

*Union of material - offered by Nature - common to all mankind - making each and every object born in Ca' Belli really unique. Thus the creation of Nature combined to the creativity of the designer to reach all our senses and the primeval and cultural roots that are part of our our DNA.*

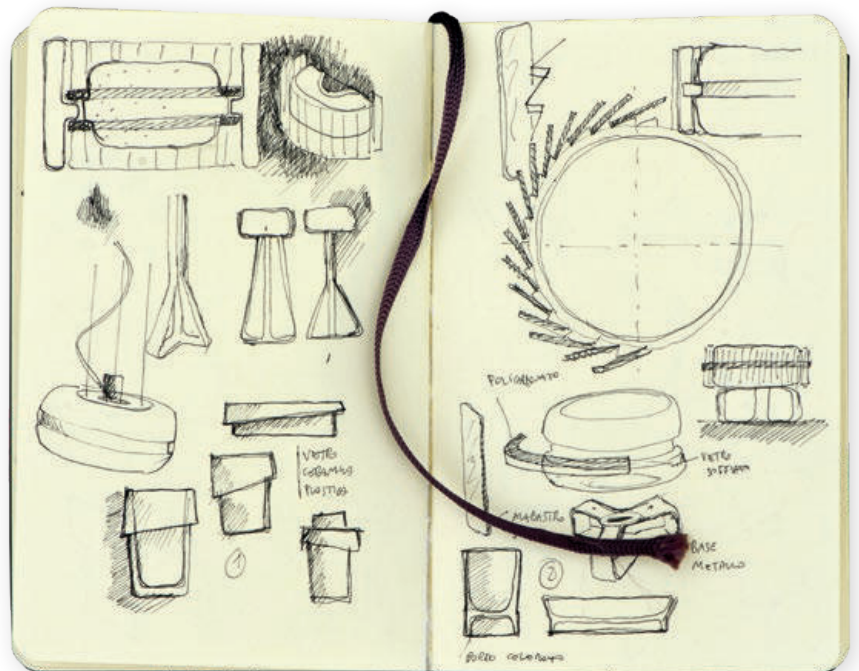



photo: Frédéric [Boccalupo]

La Ca' Belli usa da sempre materiali naturali di regioni italiane lavorati da artigiani che si tramandano il mestiere di generazione in generazione. Così pure per la lavorazione del vetro che è rimasta immutata con il passare del tempo. La tecnica ancora usata è la canna da soffio. Il risultato dipende dall'abilità e dal senso artistico dell'artigiano-vetraio. Dalla fornace viene estratto il crogiolo contenente la pasta vitrea da cui si separa il bolo, una grossa goccia. Soffiando nel tubo velocemente e ruotandolo

rapidamente si modella l'oggetto, aiutati da pinze e tiranti. Tutte le fasi sono necessariamente manuali, personali, faticose, e quindi l'oggetto finale è un pezzo unico.

Materia, innovazione, design sono i must su cui si gioca il nostro futuro. La formula sintetizza il modo di lavorare di Ca' Belli. Il nostro team coinvolge sempre artigiani, designers, progettisti, tecnici in una sorta di neo bottega della creatività che è la nostra essenza ed è l'anima del vero Made in Italy.

Ca' Belli has always used natural materials from various regions of Italy, processed by craftsmen who have passed down the trade from generation to generation. Likewise for glass processing that has not changed over time. The blowpipe technique is still used today. The end result depends on the ability and artistic skill of the glassmith. The crucible containing the molten glass is extracted from the furnace and the glob of glass is collected. The item



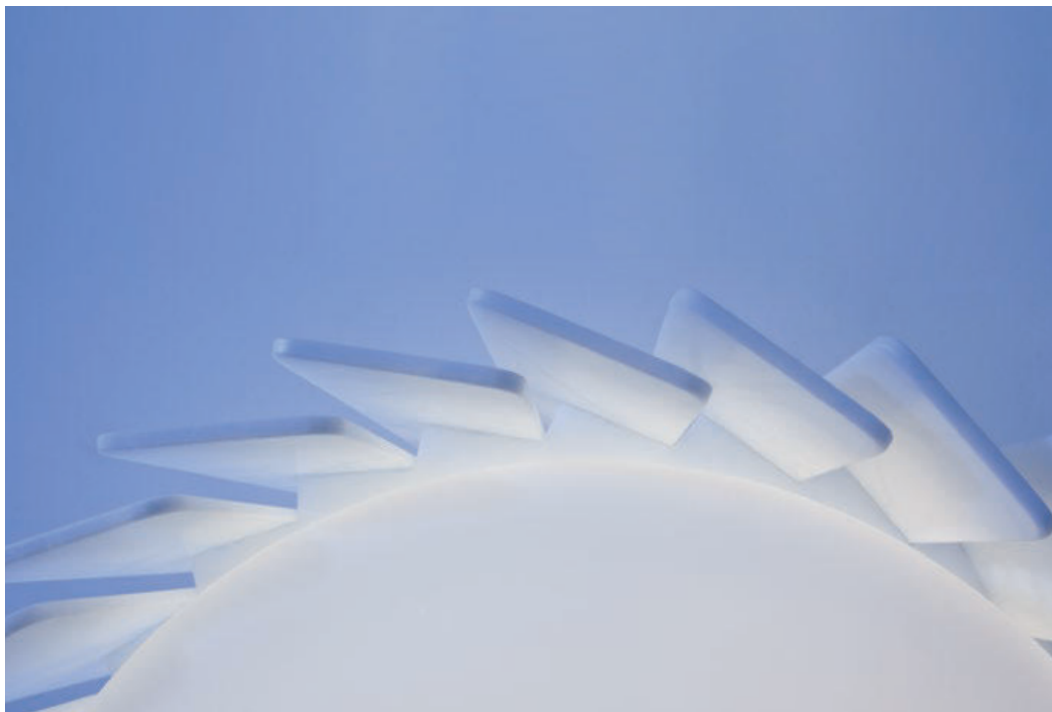

is molded by blowing quickly into the pipe whilst turning it and using tweezers and jacks. All steps must be implemented manually, personalized and laboriously. All this makes the final product unique.

Our future is based on materials, innovation and design. This formula sums up Ca' Belli's work. Our team always involves craftsmen, designers and experts in a sort of creativity workshop that is our essence and the core of Made in Italy.



micene sospensione







CONTRACT  
PIE BOOKS

FABBRICA MOBILIO TIPOGRAFICO  
VINCENZO MARTINONI  
CASTANO I MILANO

RECICLO-PIUMINO



micene tavolo







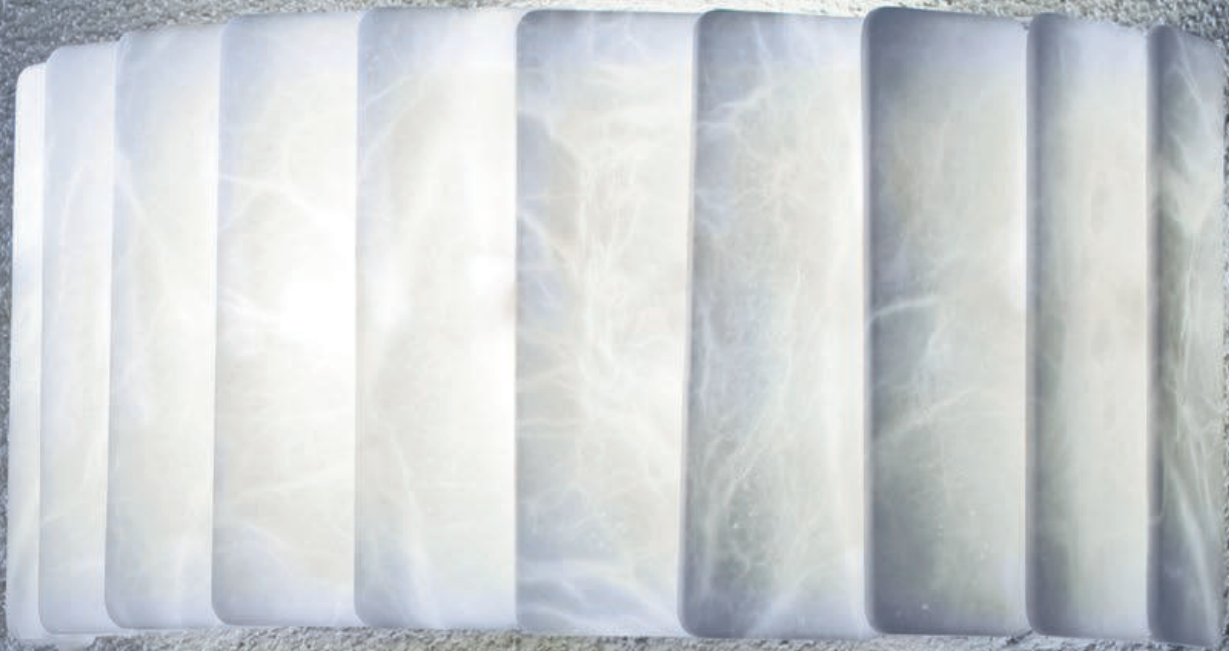



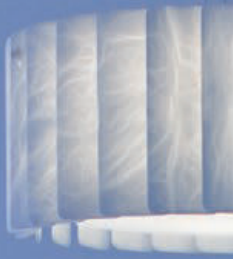

micene terra



tavolo / table

terra / floor

- a richiesta cavo di alimentazione con dimmer / power cord with dimmer  
available on demand

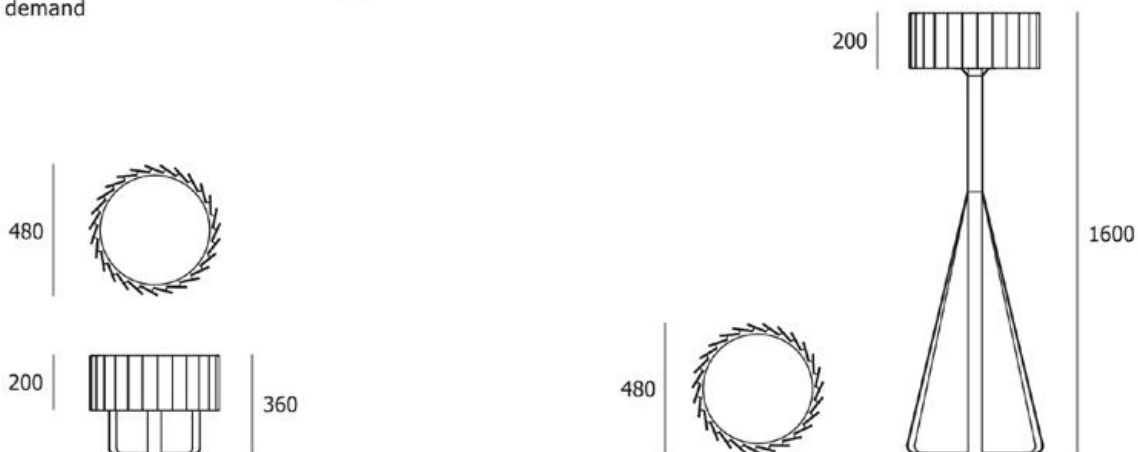

tavolo / table

14 005



alabastro  
401

001 - E27

LED MAX 12W

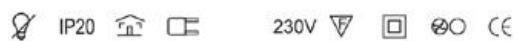

terra / floor

11 023



alabastro  
401

001 - E27

LED MAX 12W

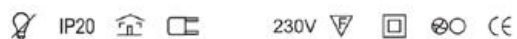

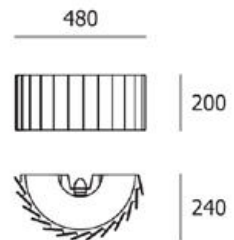
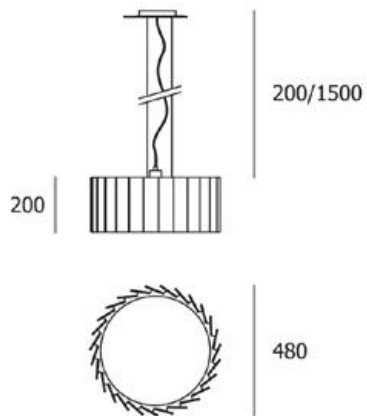

12 014



alabastro  
401

001 - E27

LED MAX 12W

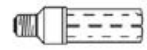

13 051



alabastro  
401

001 - E27

LED MAX 12W

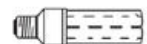







# damasco

Design by Anzalone+Bistacchi

Famiglia di lampade sospensione, tavolo, applique realizzate in acciaio verniciato e Alabastro Pietra degli Dei di incredibile qualità.

La lampada spenta evidenzia l'incredibile bellezza del marmo accesa sottolinea il disegno damascato ottenuto con taglio laser sulla lamiera d'acciaio verniciato.

---

*A collection composed of suspension, table and wall lamps made of varnished steel and the highest quality Alabastro Pietra degli Dei.*

*When the lamp is off the aesthetic qualities of the material is enhanced whilst when it is on, the light draws the attention to the underlying damask pattern obtained with laser technologies on the steel structure supporting the marble.*





d a m a s c o t a v o l o







d a m a s c o   p a r e t e



d a m a s c o   s o s p e n s i o n e



# damasco

sospensione / suspension

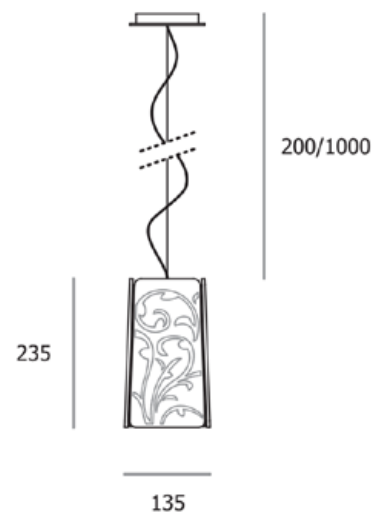

Kg. 2,9

12 018



alabastro  
401

001 - E27

LED MAX 12W



tavolo / table

parete / wall

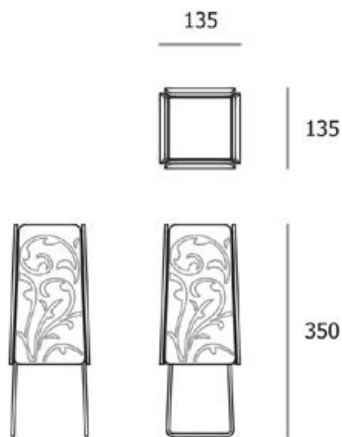

tavolo / table

Kg. 2,8

14 006



alabastro  
401

001 - E27

LED MAX 12W



 IP20 
 
 
 230V 
 

 
 CE

parete / wall

Kg. 2,5

13 054







alabastro  
401

001 - E27

LED MAX 12W



 IP20 
  
 230V 
 

 
 CE





inari 30 tavolo





# inari

Design by Marta Laudani + Marco Romanelli

Lampada da tavolo e sospensione realizzate in filo d'acciaio nichelato e Alabastro Pietra degli Dei materiale semiprezioso di eccezionale qualità. Cablata con un portalampade E27 consente l'utilizzo di lampadine alogene o a basso consumo.

Essenziale nei tratti è adatta ad ambienti sia contemporanei che classici.

---

*Table and suspension lamps made of nickel coated steel and Alabastro Pietra degli Dei, a high quality semi-precious natural material.*

*Wired with an E27 lamp holder to allow insertion of halogen or energy saving bulbs.*

*Essential lines and traits make it suitable both for contemporary and classical environments.*





inari 30 sospensione



inari 40 tavolo





inari 30 tavolo



inari 40 sospensione



tavolo 30 / table 30

sospensione 30 / suspension 30

- a richiesta cavo di alimentazione con dimmer / power cord with dimmer  
available on demand

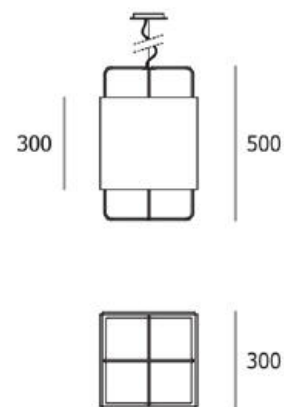
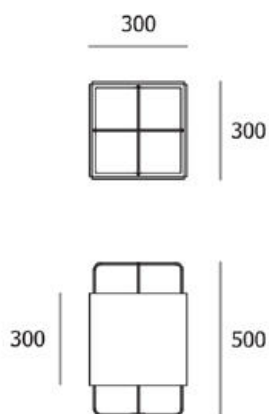

tavolo 30 / table 30

Kg. 8,2

14 008





alabastro  
401

001 - E27

LED MAX 15W



 IP20
 

 230V
 

 CE

sospensione 30 / suspension 30

Kg. 8,4

12 017







alabastro  
401

001 - E27

LED MAX 15W



 IP20
 

 230V
 

 CE

tavolo 40 / table 40

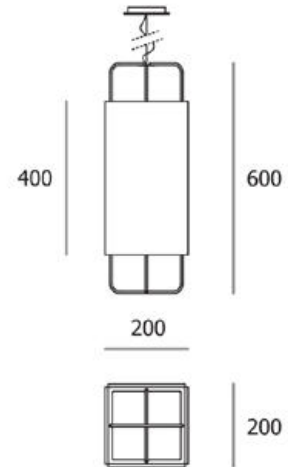
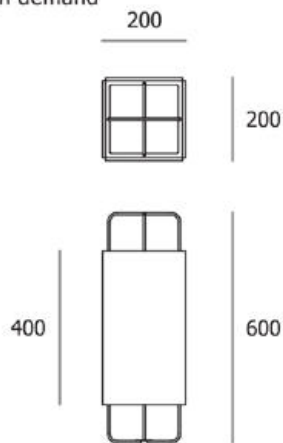
sospensione 40 / suspension 40

- a richiesta cavo di alimentazione con dimmer / power cord with dimmer  
available on demand



tavolo 40 / table 40

Kg. 7,1

14 007

alabastro  
401

001 - E27

LED MAX 15W

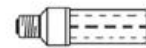

230V

sospensione 40 / suspension 40

Kg. 7,2

12 016

alabastro  
401

001 - E27

LED MAX 15W

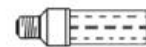

230V









# lemni

Design by Anzalone + Bistacchi

Lampada da parete realizzata in tre moduli: 15-30-45cm.

Preziosi i materiali utilizzati: Alabastro Pietra degli Dei e Ardesia che insieme formano un connubio di eccezionale impatto visivo.

Le fonti luminose LED o fluorescenza consentono all'apparecchio un utilizzo pressoché illimitato.

---

*Wall lamps in three lengths: 15-30-45cm.*

*Precious materials: Alabastro Pietra degli Dei and Slate Stone used in symbiotic harmony to obtain a highly effective visual impact.*

*The light sources, LED or fluorescent allow for endless uses.*



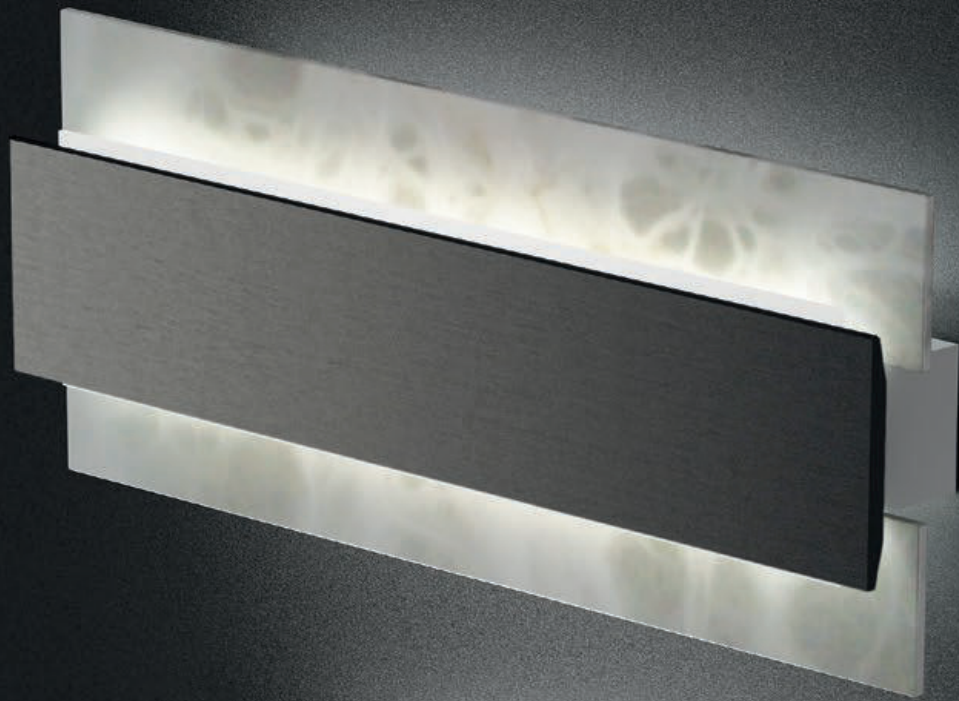







lemni 15

Kg. 0,9

**13 055**



alabastro/ardesia  
**401**

**001** - LED

doppia striscia led 2x2,7W  
double led reglette 2x2,7W



LED INCLUSO  
LED INCLUDED

A IP20 230V

lemni 30

Kg. 1,8

**13 056**



alabastro/ardesia  
**401**

**001** - LED

doppia striscia led 2x5W  
double led reglette 2x5W



LED INCLUSO  
LED INCLUDED

A IP20 230V

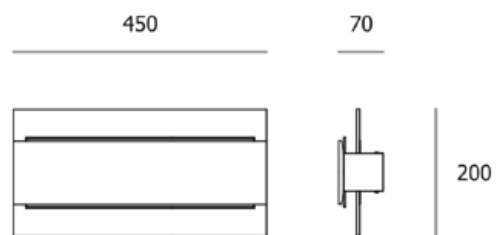

---

lemni 45

Kg. 2,7

**13 057**



alabastro/ardesia  
**401**

**001** - LED

doppia striscia led 2x5,7W  
double led reglette 2x5,7W



LED INCLUSO  
LED INCLUDED



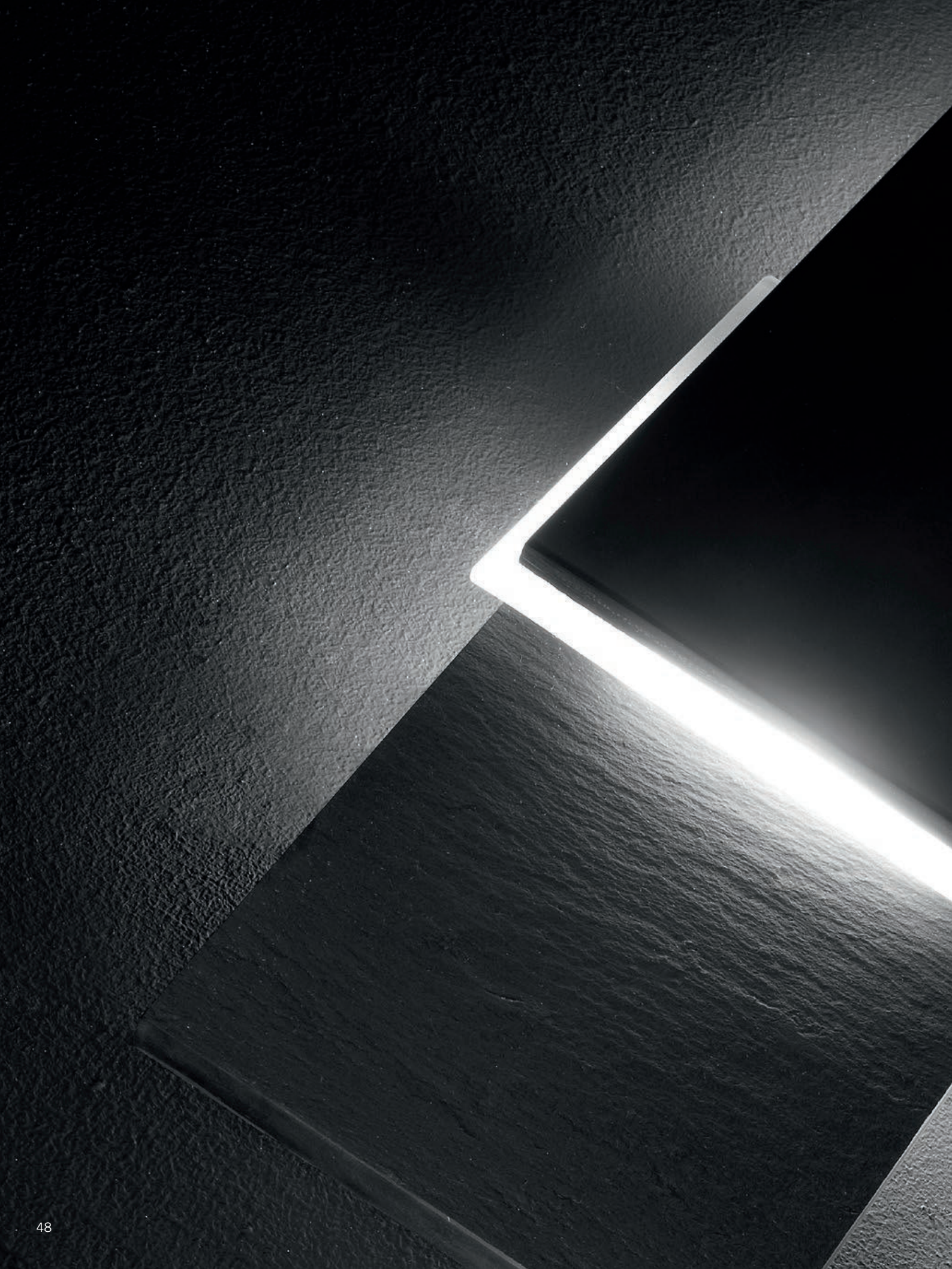



SISSI

Lampada scultura da parete per interni realizzata in ardesia lavorata con diverse finiture; la pietra frammentata in diversi riquadri posti su varie inclinazioni illuminata crea sulla parete una luce radente che sottolinea la texture dell'ardesia.

*Wall lamp series, sculptures for indoor use made of Slate Stone, shiny or natural cleft; the stone squares have different inclinations to create the effect of indirect grazing light highlighting the texture of the slates of stone.*

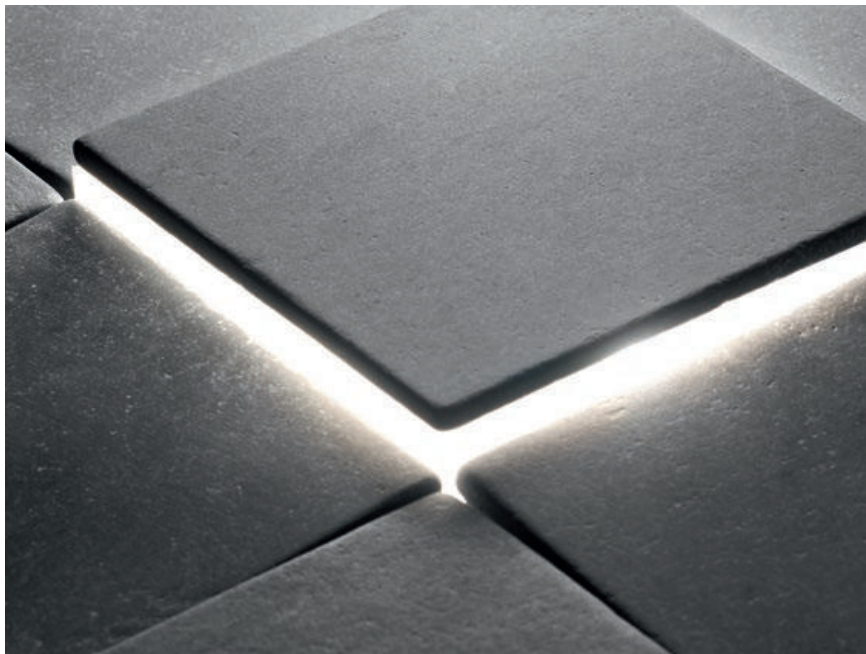



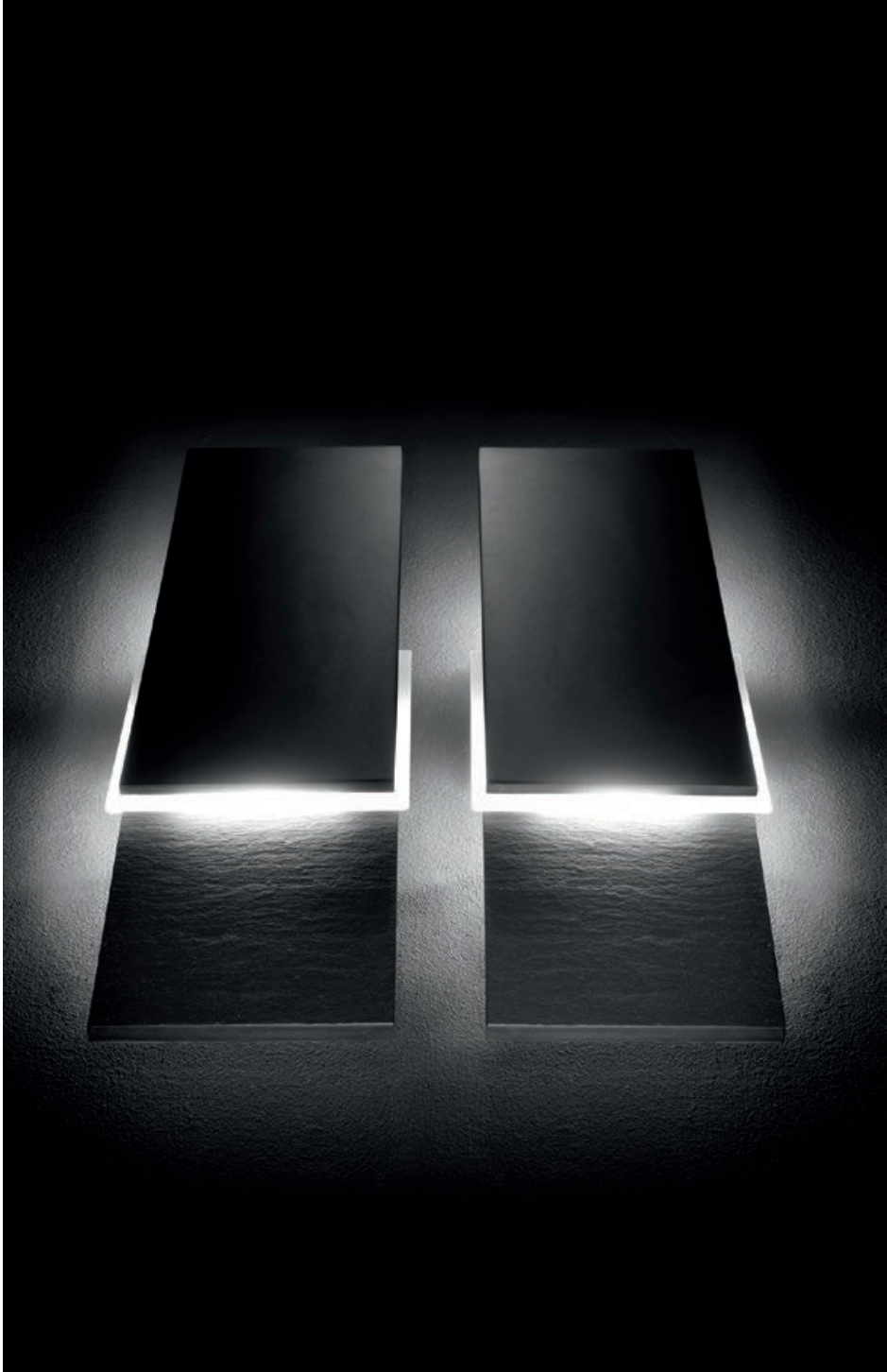

z e r o   s i s s i



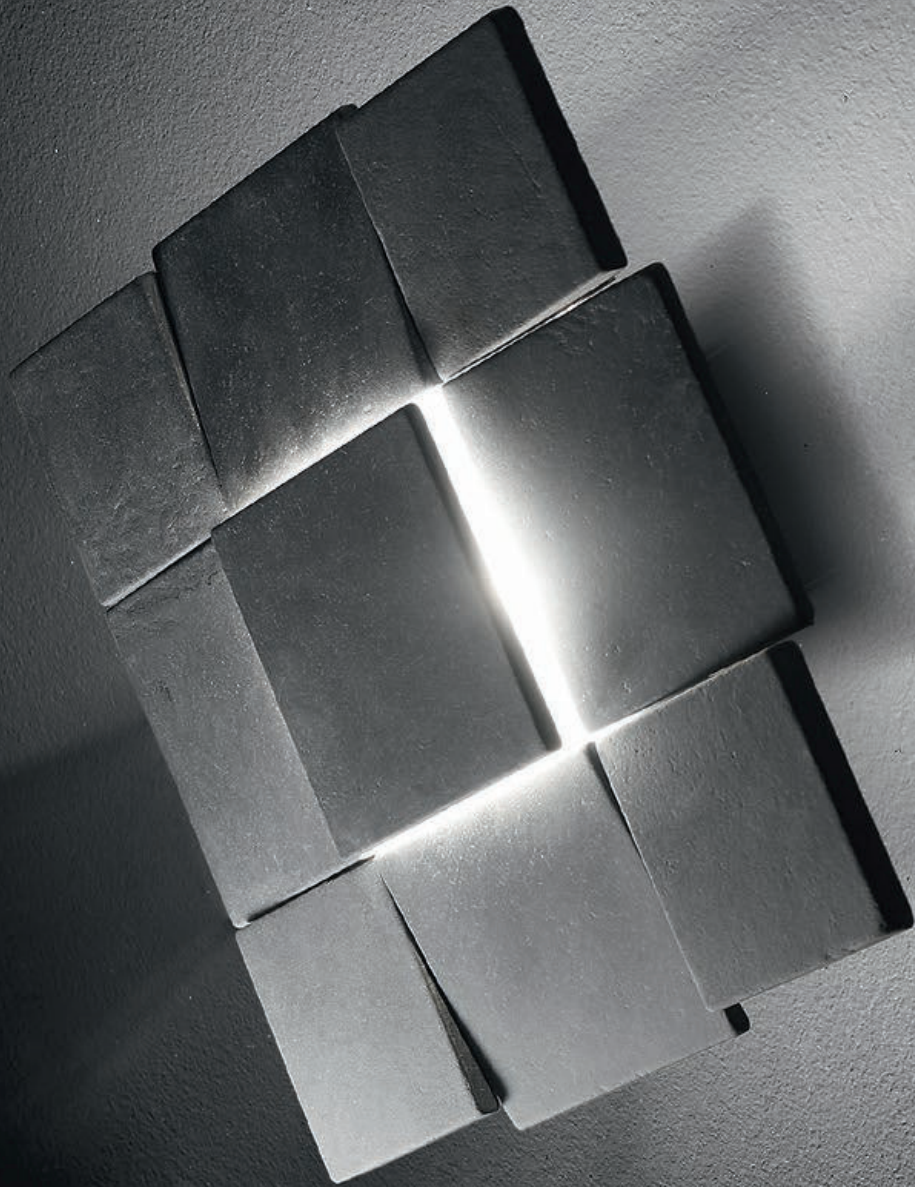







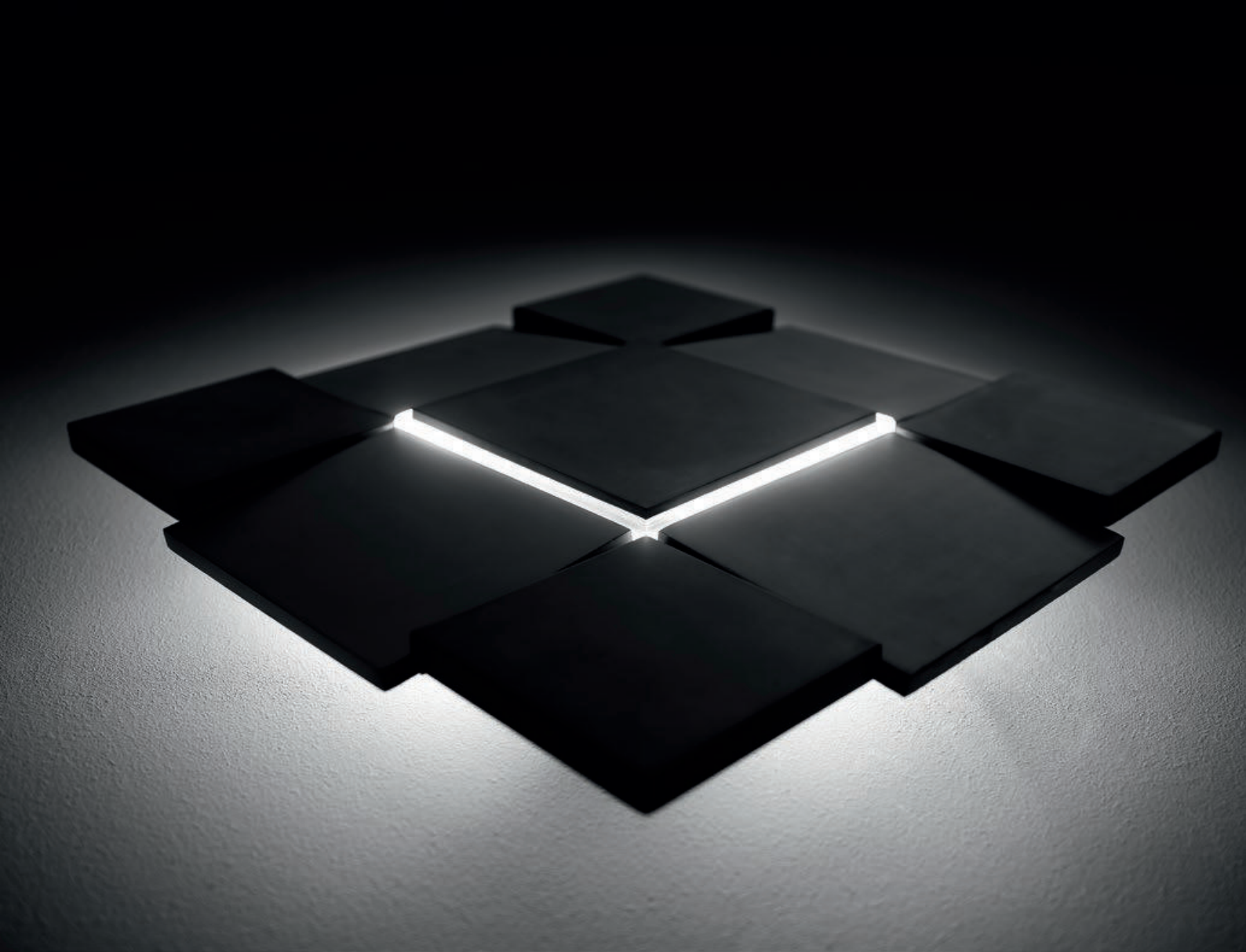



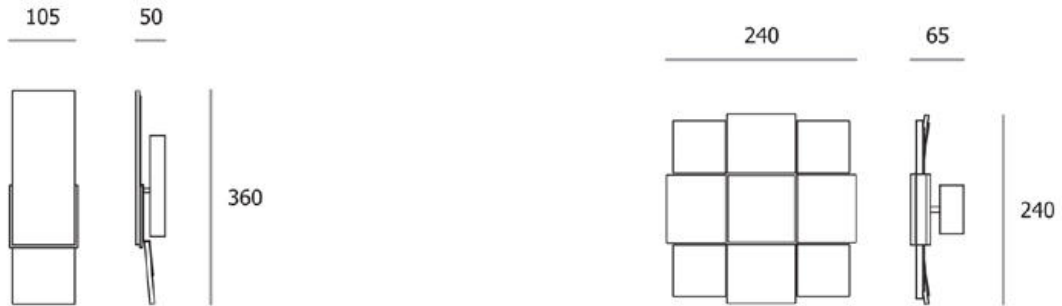



zero sissi

Kg. 1,5

**13 006**





ardesia levigata **011**  
 ardesia a spacco **012**

**001 - G9**      LED MAX9W      

---

**002 - LED**      doppia striscia led 2x4W  
double led reglette 2x4W      

LED INCLUSO  
LED INCLUDED

A  IP20       230V        

piccola sissi

Kg. 2

**13 005**

ardesia levigata **011**  
 ardesia a spacco **012**

**001 - G9**      LED MAX9W      

 IP20       230V        

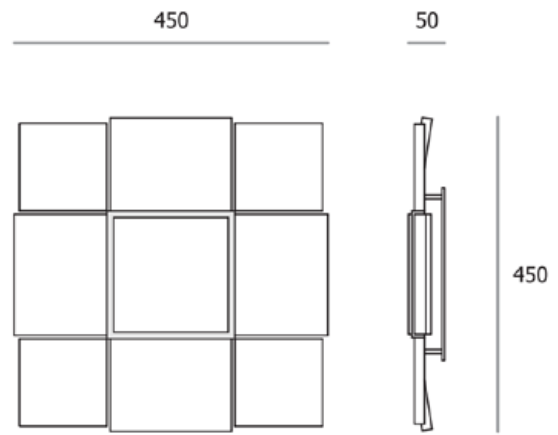

13 013

-  ardesia levigata  
**011**
-  leccese  
**070**
-  rosso mattone  
**071**
-  antracite  
**073**
-  marrone  
**074**

001 - G10q

Circolina led 12W  
Circular led 12W

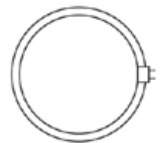





little

## little

Corpo luminoso per interni in pietra leccese ricavata da concio, crea una luce d'accento adatta per ambientazioni classiche o contemporanee. Identico nella concezione Little maxi, più grande e adatta anche ad un uso esterno.

*Spot light for indoor use made of Lecce Stone obtained from ashlar blocks, accent light suitable for classical or contemporary environments. The same concept applies to Little Maxi, the bigger version that is suitable for outdoor use as well.*

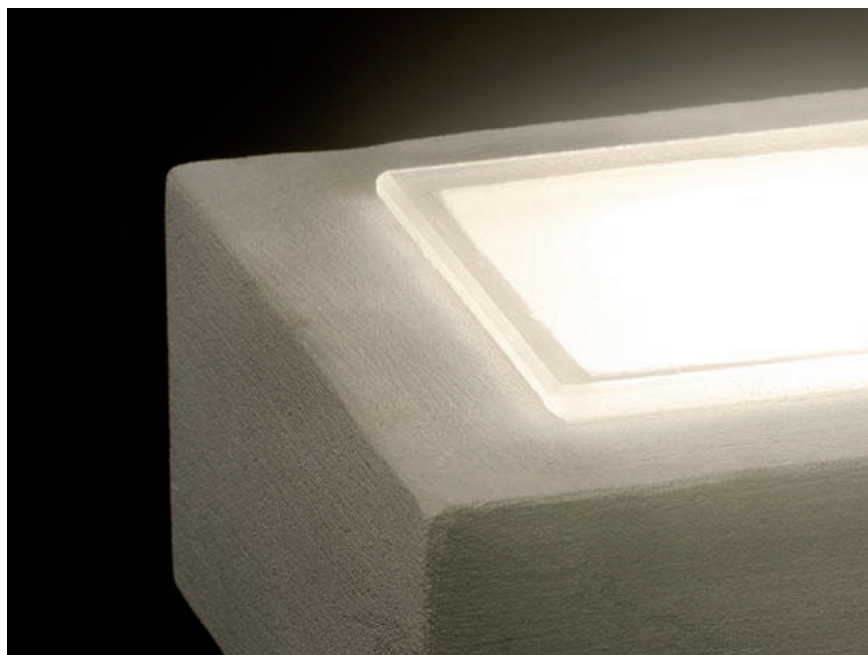





l i t t l e   m a x i



little

Kg. 0,8

**13 018**

-  leccese **070**
-  rosso mattone **071**
-  antracite **073**
-  marrone **074**

**001 - G9**      LED MAX9W



 IP33
 
 230V
 



little maxi

Kg. 2,6

**13 020**

-  leccese **070**
-  rosso mattone **071**
-  antracite **073**
-  marrone **074**

**001 - G9**      LED MAX 12W



 IP55
 

 230V
 







# quadra

Lampada in pietra leccese; la pietra che è strutturale, conferisce alla lampada grande matericità e presenza. Prevista in diverse versioni può essere collocata a parete o soffitto.

*Lamp made of Lecce stone here used  
as structure for a great tactile and visual impact.  
Ceiling and wall versions available.*





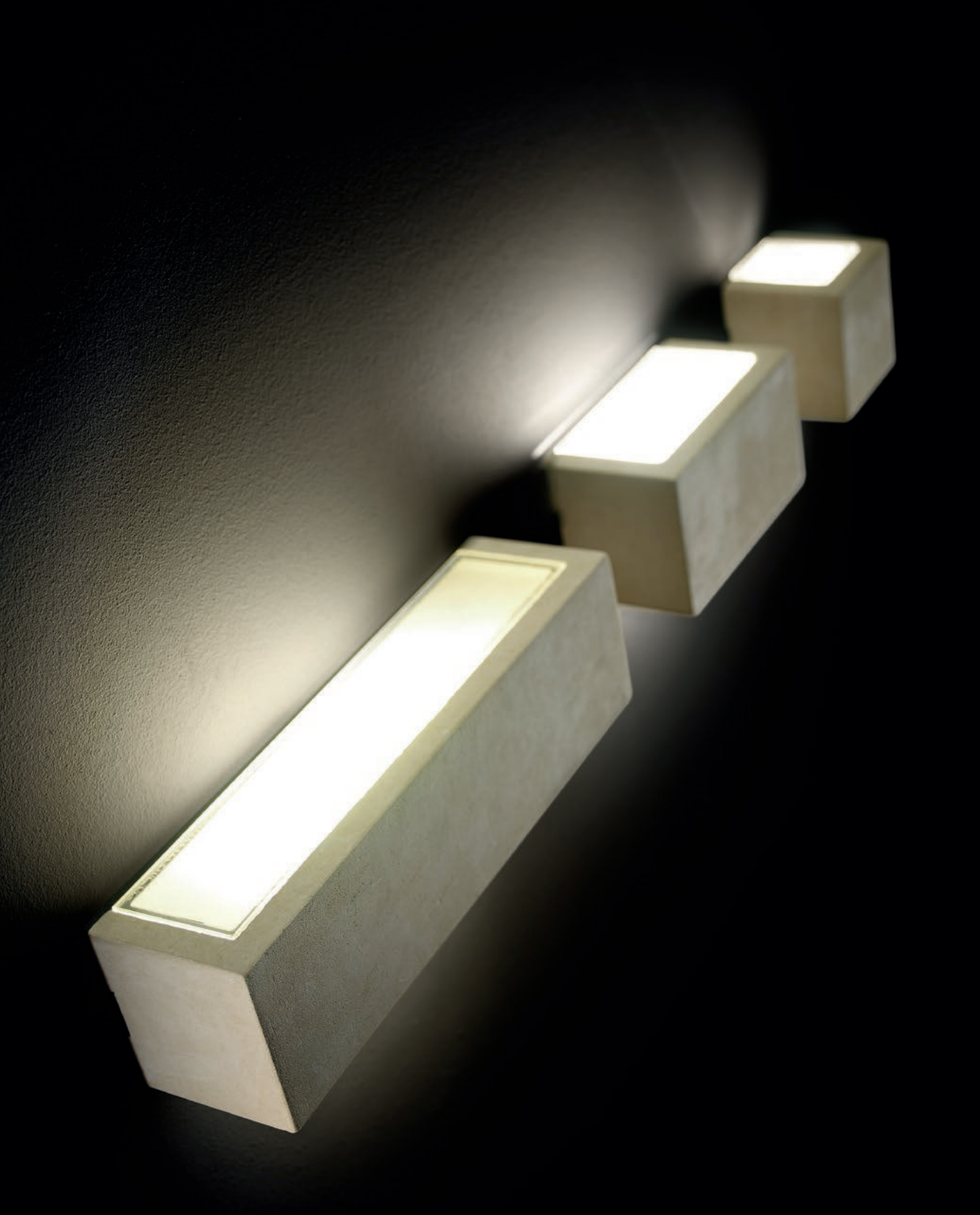

quadra parete 110 - 250 - 400







quadra soffitto 160



quadra soffitto 290





quadra soffitto 420









quadra parete 110

Kg. 1,5

**13 027**

-  leccese **070**
-  rosso mattone **071**
-  antracite **073**
-  marrone **074**

**001 - G9**      LED MAX 6W







 IP33  230V   

quadra parete 250

Kg. 2,3

**13 028**

-  leccese **070**
-  rosso mattone **071**
-  antracite **073**
-  marrone **074**

**001 - E27**      LED MAX 12W

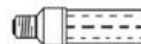

A  IP33  230V   

# quadra parete 400

---

400



110



110

quadra parete 400

Kg. 3,3

**13 029**



leccese  
**070**



rosso mattone  
**071**



antracite  
**073**



marrone  
**074**

**002** - E27

LED MAX 2X12W



A  IP33 

230V



quadra soffitto 160

quadra soffitto 290

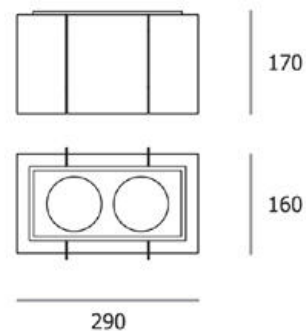
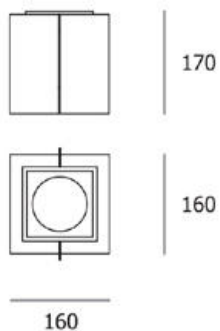

quadra soffitto 160

Kg. 4

12 010



leccese  
**070**



rosso mattone  
**071**



antracite  
**073**



marrone  
**074**

001 - E27

LED MAX 12W



A  IP20  230V  CE

quadra soffitto 290

Kg. 7,5

12 011



leccese  
**070**



rosso mattone  
**071**



antracite  
**073**



marrone  
**074**

001 - E27



2XLED MAX 12W

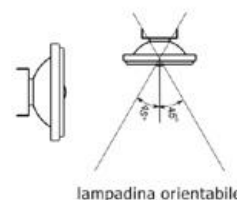

002 - G53

2XLED AR111 MAX 12W



A  IP20  230V - 12 V  CE

# quadra soffitto 420

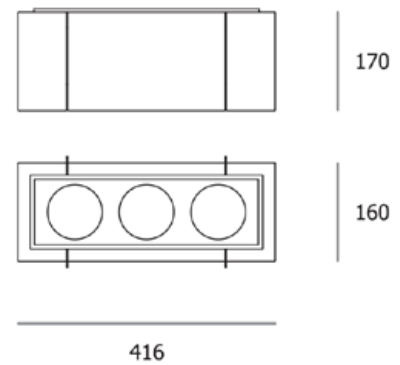

quadra soffitto 420

Kg. 10

12 012



leccese  
**070**

**001** - E27

3XLED MAX 12W



rosso mattone  
**071**



antracite  
**073**



marrone  
**074**

**002** - G53

3XLED AR111 MAX 12W

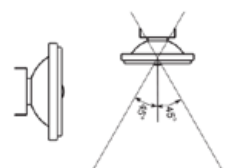

lampadina orientabile

A IP20 230V - 12 V





## elettra - repetita

Lampada da parete per interni ed esterni con grado di protezione IP55 costituita da semicerchi in vetro e pietra leccese. Dolce nei tratti, morbida nei contorni crea una luce diffusa. Identica nella concezione la Repetita dalla quale differisce nel numero degli elementi.

*Lamp Wall for indoor and outdoor use with protection grade IP55, composed of semicircles of glass and Lecce Stone. Soft rounded traits to create a diffused light. The same concept applies to Repetita, different only for the number of elements.*





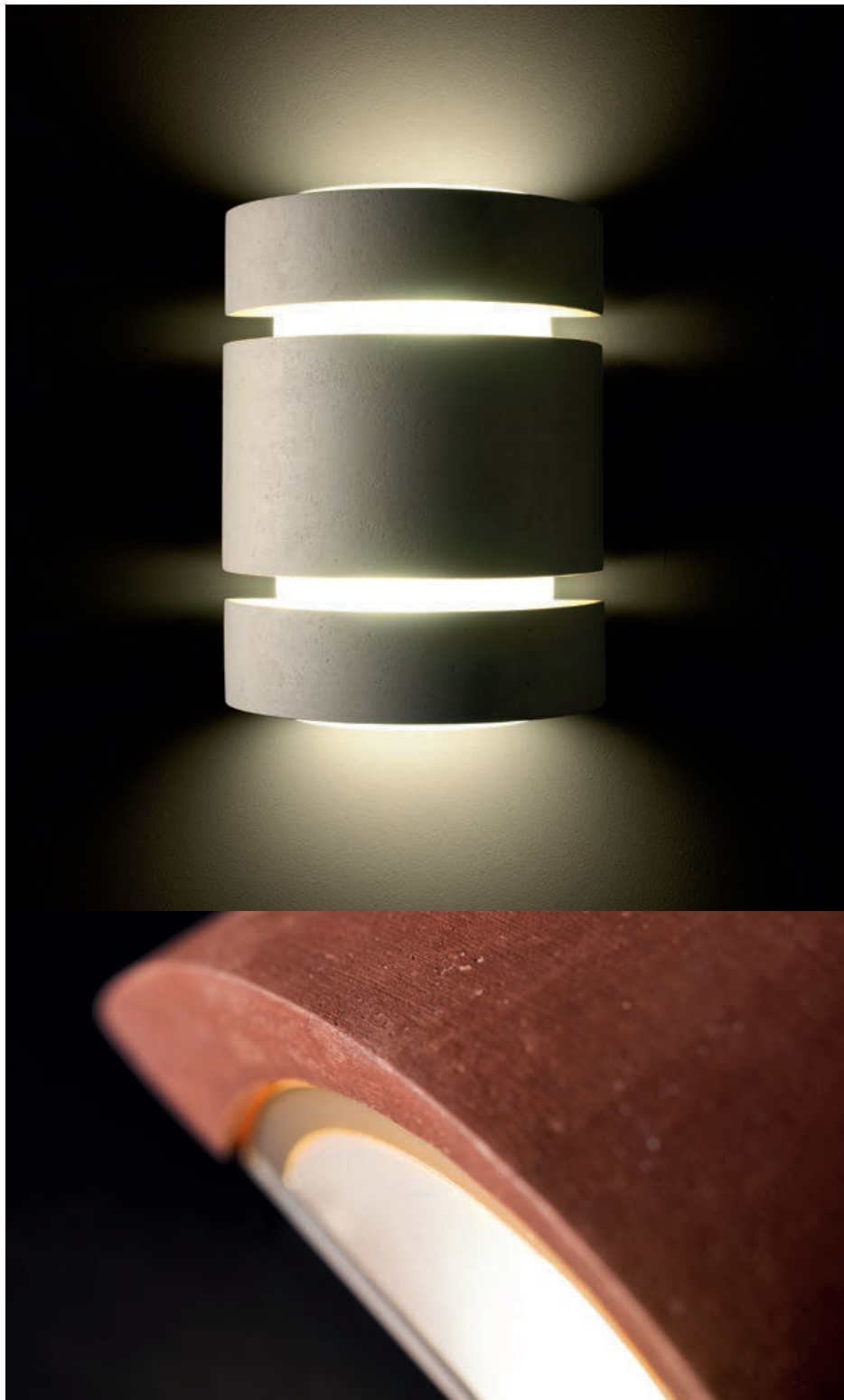

e l e t t r a



repetita











versione con diffusori in vetro / model with glass diffusers

versione con diffusori in metacrilato / model with plexiglass diffusers

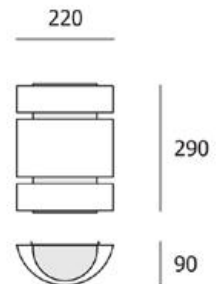
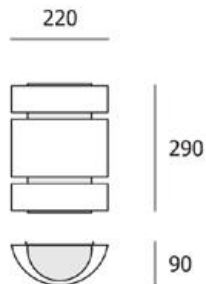

elettra (versione con diffusori in vetro / model with glass diffusers)

Kg. 4,5

13 014



001 - E27

LED MAX 2X12W

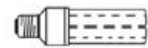

elettra (versione con diffusori in metacrilato / model with plexiglass diffusers)

Kg. 4,5

13 015



001 - E27

LED MAX 2X12W



versione con diffusori in vetro / model with glass diffusers

versione con diffusori in metacrilato / model with plexiglass diffusers

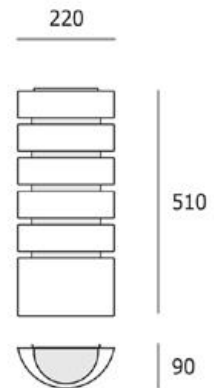
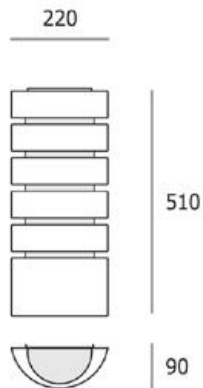

repetita (versione con diffusori in vetro / model with glass diffusers)

Kg. 9

13 023



002 - LED

doppia striscia led 2x5,7W  
double led reglette 2x5,7W  
LED INCLUSO  
LED INCLUDED



repetita (versione con diffusori in metacrilato / model with plexiglass diffusers)

Kg. 9

13 024



002 - LED

doppia striscia led 2x5,7W  
double led reglette 2x5,7W  
LED INCLUSO  
LED INCLUDED







## dada - dada maxi

Corpo lampada da parete utilizzabile sia da interni che da esterni con grado di protezione IP 55, realizzata in pietra leccese e vetro temperato. La sua forma semicircolare molto pulita si adatta ad ogni tipo di esigenza progettuale. Due le versioni disponibili.

*Sconce lamp suitable for indoor and outdoor use with protection grade IP55 made of Lecce Stone and rolled glass.*

*Semicircular shape and clean design make it perfect for any environment. Two versions available.*





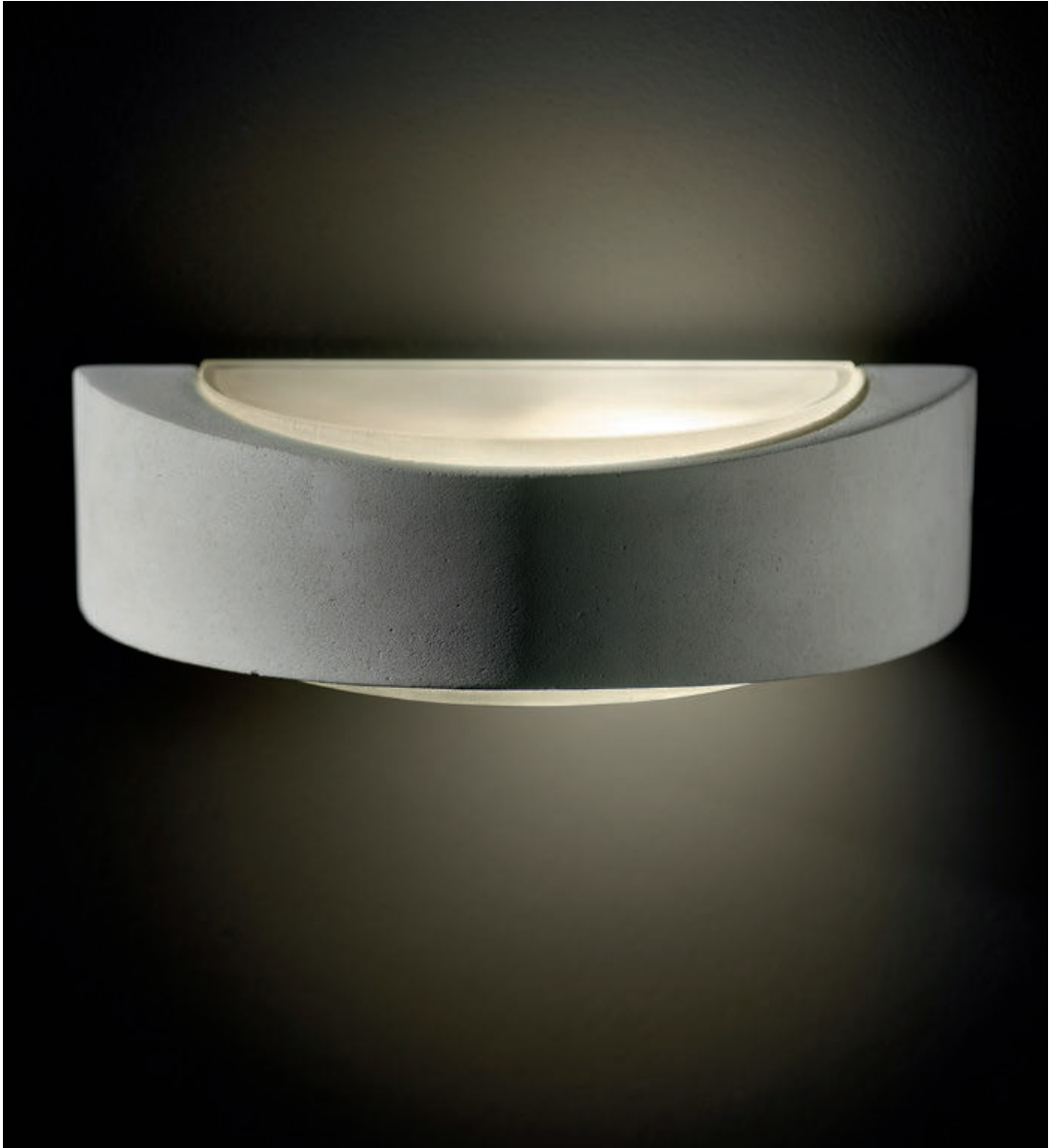

d a d a







dada maxi





dada

Kg. 2,2

**13 017**

-  leccese **070**
-  rosso mattone **071**
-  antracite **073**
-  marrone **074**

**003 - E27**      LED MAX 12W



dada maxi

Kg. 5

**13 026**

-  leccese **070**
-  rosso mattone **071**
-  antracite **073**
-  marrone **074**

**001 - E27**      LED MAX 2X12W







pedro

# pedro

Lampada da soffitto e parete per interni ed esterni dal fascino discreto, realizzata in pietra leccese, vetro float e base in alluminio.

*Ceiling and wall lamp for indoor and outdoor use that emanates a subtle appeal, made of Lecce Stone, Float glass and aluminum base.*







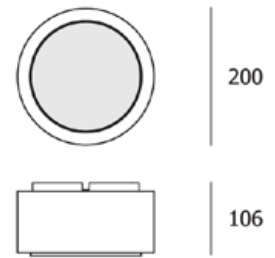

pedro

Kg. 4,3

13 016



leccese  
**070**



rosso mattone  
**071**



antracite  
**073**



marrone  
**074**

**001 - LED**

LED MODULE 8.7W

LED INCLUSO  
LED INCLUDED





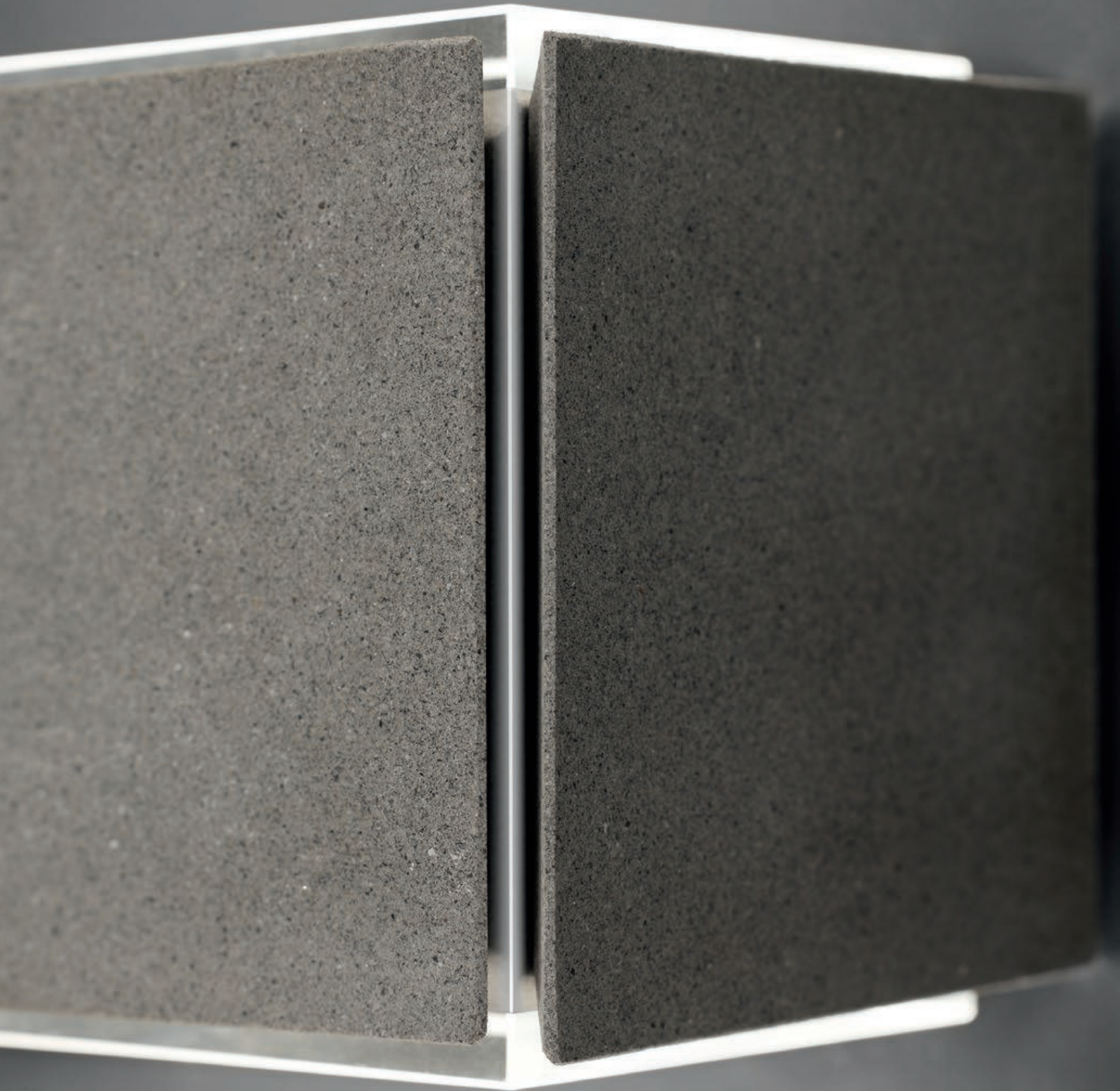

## metro

Corpo lampada in cui la pietra naturale è applicata su una struttura di alluminio lucidato. Lineari, essenziali nei tratti, sono lampade d'accento che possono essere montate sia singolarmente che in serie. Presente in diverse versioni, da parete, da soffitto, per interni e per esterni.

*In this series of lamps the natural stone slabs are applied onto a structure made of anodized aluminum. Linear and essential traits for these accent light fixtures that can be used individually or grouped. Wall and ceiling, indoor and outdoor versions available.*

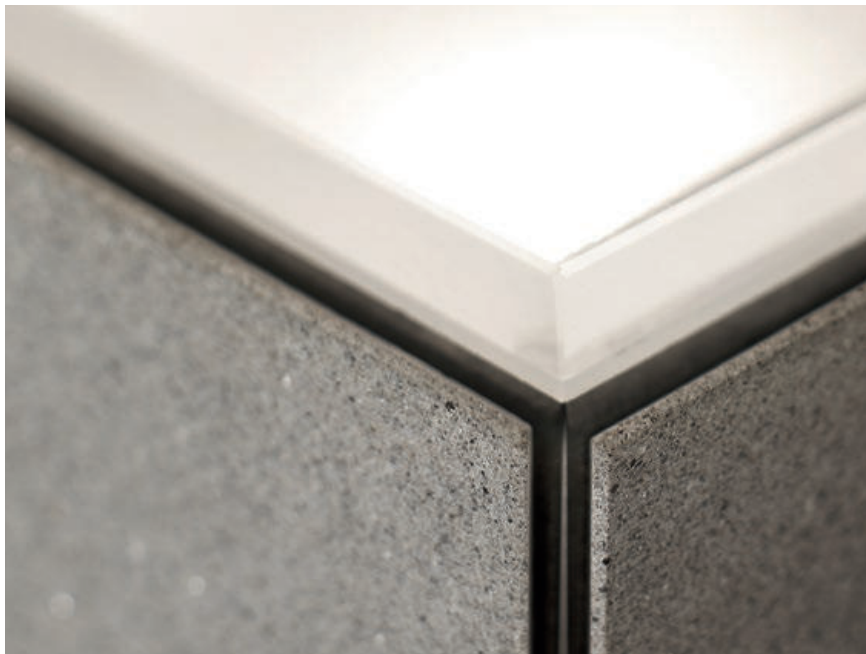





metro quadro



metro cubo



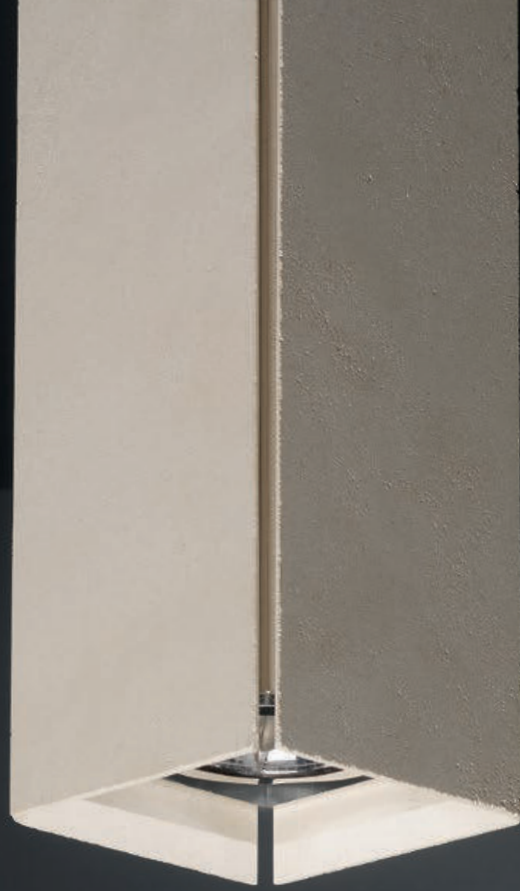

metro 25







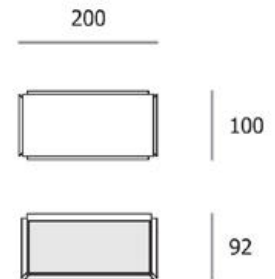
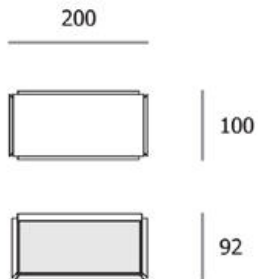



metro quadro

Kg. 2

**13 010**

-  ardesia levigata **011**
-  serena **020**
-  grey **030**
-  basaltina **040**
-  rosso king **050**
-  crema **060**

**001** - E27      LED MAX 12W

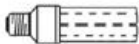







IP33      230V         

metro quadro IP55







Kg. 2

**13 012**

-  ardesia levigata **011**
-  serena **020**
-  grey **030**
-  basaltina **040**
-  rosso king **050**
-  crema **060**

**001** - E27      LED MAX 12W



A      IP55         230V         



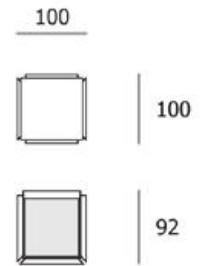
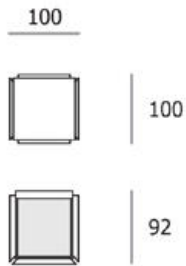



metro cubo



Kg. 1,3

**13 007**

-  ardesia levigata **011**
-  serena **020**
-  grey **030**
-  basaltina **040**
-  rosso king **050**
-  crema **060**

**001** - G9      LED MAX 6W



IP33      230V         

metro cubo IP55

Kg. 1,3

**13 009**

-  ardesia levigata **011**
-  serena **020**
-  grey **030**
-  basaltina **040**
-  rosso king **050**
-  crema **060**

**001** - G9      LED MAX 6W





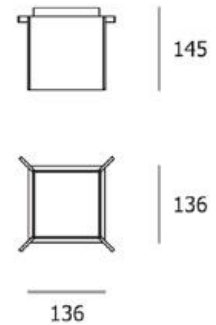
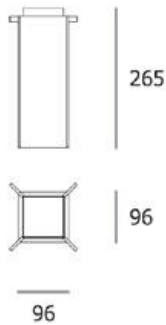



IP55            230V         



metro 25

Kg. 3

12 003

-  ardesia levigata  
**011**
-  serena  
**020**
-  grey  
**030**
-  basaltina  
**040**
-  rosso king  
**050**
-  crema  
**060**

002 - E27







LED max 10W



metro 130

Kg. 2,5

12 005

-  ardesia levigata  
**011**
-  serena  
**020**
-  grey  
**030**
-  basaltina  
**040**
-  rosso king  
**050**
-  crema  
**060**

002 - E27

LED max 10W





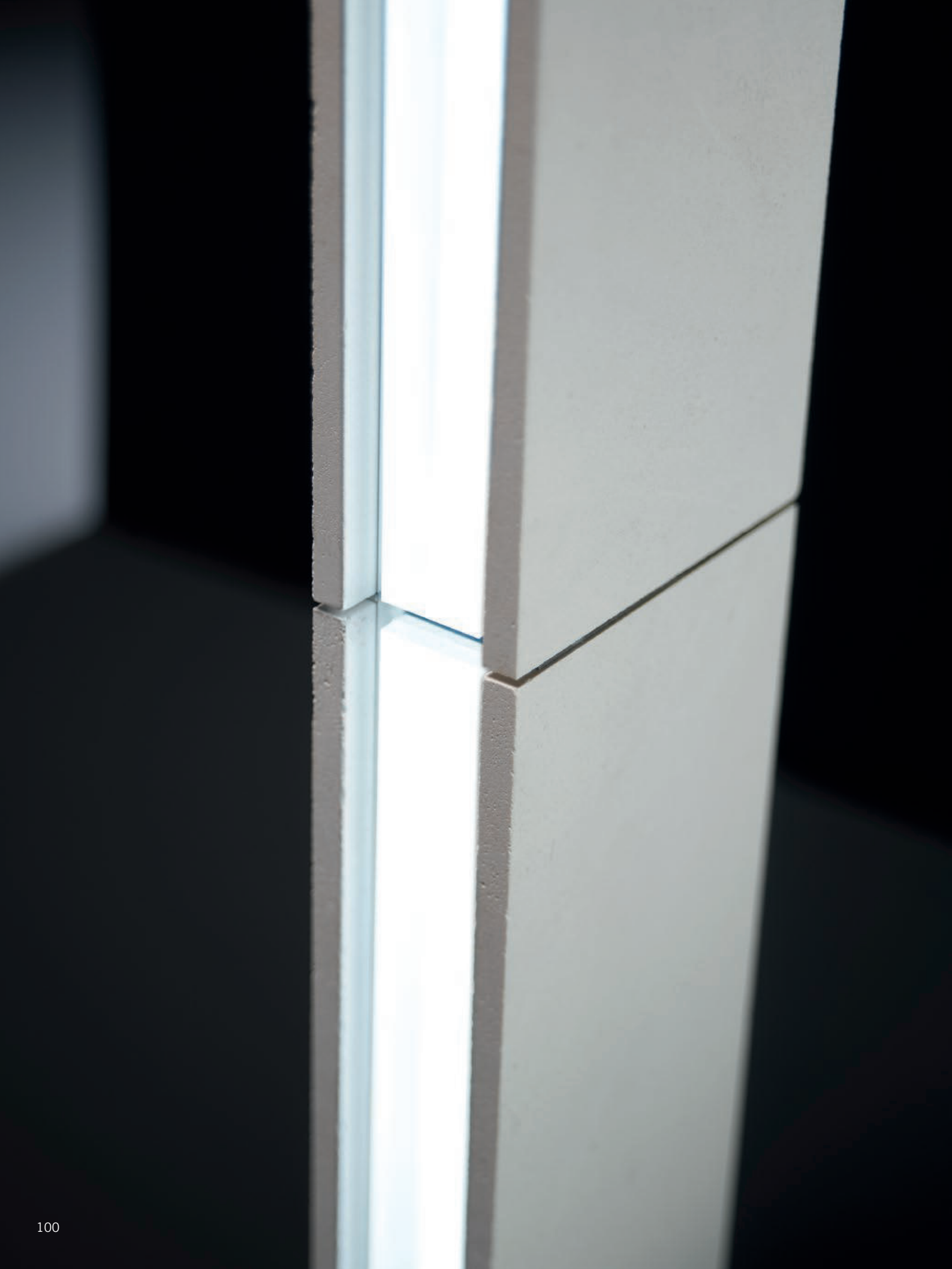

# giglia

Lampada in pietra naturale per esterni, progettata a singola e doppia emissione vive naturalmente negli spazi architettonici minimali. È prevista in quattro dimensioni che consentono una grande possibilità di utilizzo.

*In this series of lamps for outdoor use, the natural stone slabs are applied onto a structure. Single or double light emission versions available. This fixture lives well in minimalist architectural spaces and comes in four different heights to allow for a greater range of uses.*





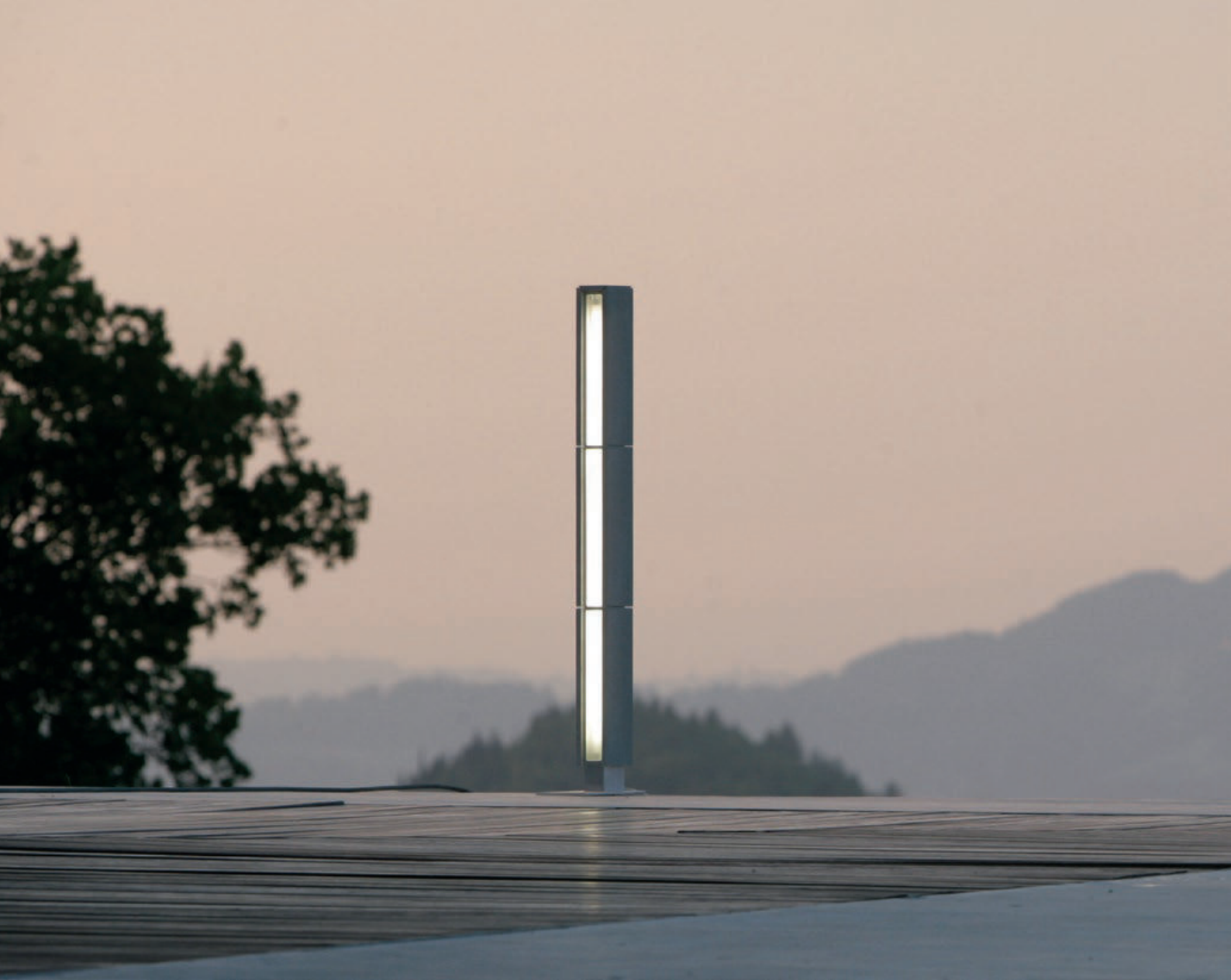

g i g i a 9 0





g i g i a 6 0





S.E. (singola emissione / single light emission)  
D.E. (doppia emissione / double light emission)

S.E. (singola emissione / single light emission)  
D.E. (doppia emissione / double light emission)

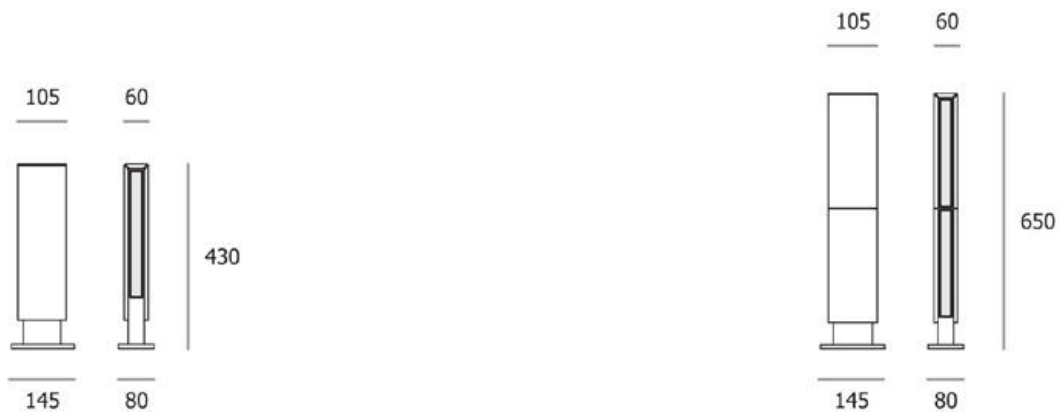

gigia 30 (per specifiche di ancoraggio a terra vedi pag.186 / go to page 186 for grounding/anchoring instructions)

Kg. 3,5

<p><b>11 007 - S.E.</b> <b>11 008 - D.E.</b></p>		serena <b>020</b>	<p><b>002 - LED</b></p>	S.E.	striscia led 4,2W led reglette 4,2W	
		grey <b>030</b>		D.E.	doppia striscia led 2x4,2W double led reglette 2x4,2W	
		basaltina <b>040</b>		LED INCLUSO LED INCLUDED		
		rosso king <b>050</b>				
		crema <b>060</b>				
		leccese <b>070</b>				

IP55 230V

gigia 60 (per specifiche di ancoraggio a terra vedi pag.186 / go to page 186 for grounding/anchoring instructions)

Kg. 8

<p><b>11 005 - S.E.</b> <b>11 006 - D.E.</b></p>		serena <b>020</b>	<p><b>002 - LED</b></p>	S.E.	striscia led 8,4W led reglette 8,4W	
		grey <b>030</b>		D.E.	doppia striscia led 2x8,4W double led reglette 2x8,4W	
		basaltina <b>040</b>		LED INCLUSO LED INCLUDED		
		rosso king <b>050</b>				
		crema <b>060</b>				
		leccese <b>070</b>				

IP55 230V

# gigia 90

# gigia 120



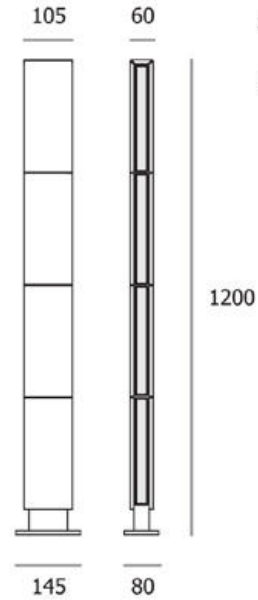
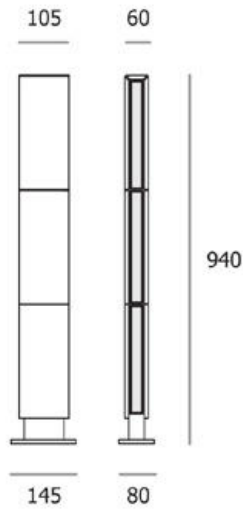



S.E. (singola emissione / single light emission)  
D.E. (doppia emissione / double light emission)







S.E. (singola emissione / single light emission)  
D.E. (doppia emissione / double light emission)

gigia 90 (per specifiche di ancoraggio a terra vedi pag.186 / go to page 186 for grounding/anchoring instructions)

Kg. 11

<b>11 003 - S.E.</b> <b>11 004 - D.E.</b>	 serena <b>020</b>	<b>002 - LED</b>	S.E. striscia led 12,6W led reglette 12,6W <hr/> D.E. doppia striscia led 2x12,6W double led reglette 2x12,6W  LED INCLUSO LED INCLUDED	
	 grey <b>030</b>			
	 basaltina <b>040</b>			
	 rosso king <b>050</b>			
	 crema <b>060</b>			
	 leccese <b>070</b>			



























gigia 120 (per specifiche di ancoraggio a terra vedi pag.186 / go to page 186 for grounding/anchoring instructions)

Kg. 13

<b>11 001 - S.E.</b> <b>11 002 - D.E.</b>	 serena <b>020</b>	<b>002 - LED</b>	S.E. striscia led 14,4W led reglette 14,4W <hr/> D.E. doppia striscia led 2x14,4W double led reglette 2x14,4W  LED INCLUSO LED INCLUDED	
	 grey <b>030</b>			
	 basaltina <b>040</b>			
	 rosso king <b>050</b>			
	 crema <b>060</b>			
	 leccese <b>070</b>			





l u c c i o l o 1 3 0

# lucciolo

Lampada in pietra leccese per esterno con grado di protezione IP55 formata da un cilindro in pietra avente tre fori asolati dai quali fuoriescono fasci di luce emessi dalla sorgente interna.  
È presente in due versioni Lucciolo e Lucciolo 130.

*Lamp made of Lecce Stone, protection rating IP-55, composed of a stone cylinder having three loopholes irradiating beams of light. Available in two versions, Lucciolo and Lucciolo 130.*









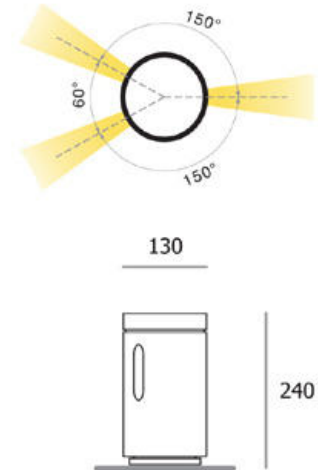
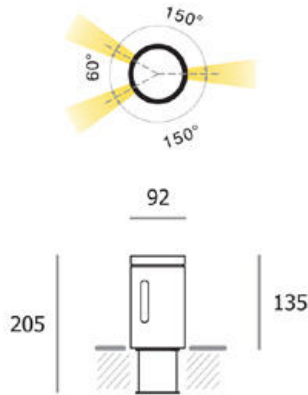

luciollo

Kg. 1,5

<b>11 009</b>	 leccese <b>070</b>	<b>001 - E27</b>	LED MAX 10W	
	 rosso mattone <b>071</b>			
	 antracite <b>073</b>			
	 marrone <b>074</b>			



luciollo 130 (per specifiche di ancoraggio a terra vedi pag.186 / go to page 186 for grounding/anchoring instructions)

Kg. 3,2

<b>11 010</b>	 leccese <b>070</b>	<b>001 - E27</b>	LED MAX 12W	
	 rosso mattone <b>071</b>			
	 antracite <b>073</b>			
	 marrone <b>074</b>			



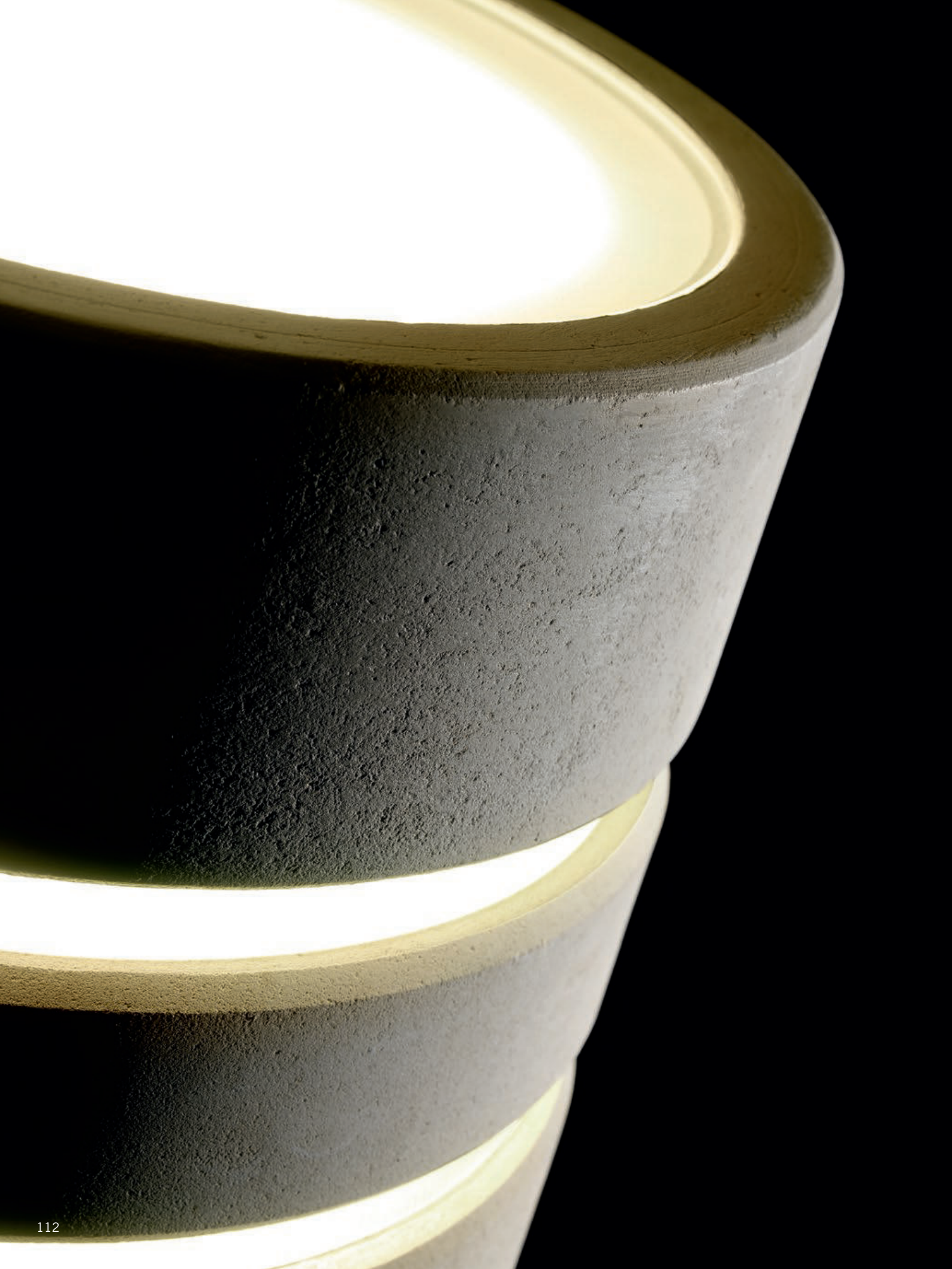

# mezzanotte

La serie Mezzanotte è stata pensata per consentire al progettista di ottenere delle lampade personalizzate in base alle proprie esigenze, infatti l'altezza dei vari elementi consente di ottenere corpi luminosi in diverse altezze e composizioni, utilizzando vetro in lastra, pietra leccese, pietra lavica o all'occorrenza pietre proposte dal cliente.

*The Mezzanotte series have been designed to allow the user to obtain a personalised lamp fit to suit his own particular needs. In fact the different combinations of its basic elements make it possible to obtain lamps in varying heights and compositions using; plate glass, Lecce stone or Lava stone or even stones proposed by the client.*

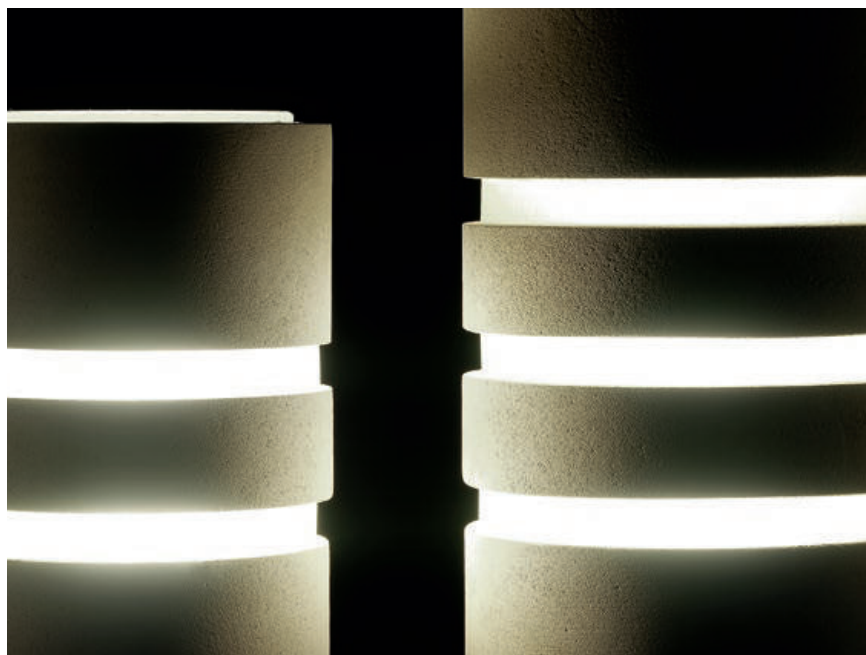





mezzanotte 130







mezzanotte 170



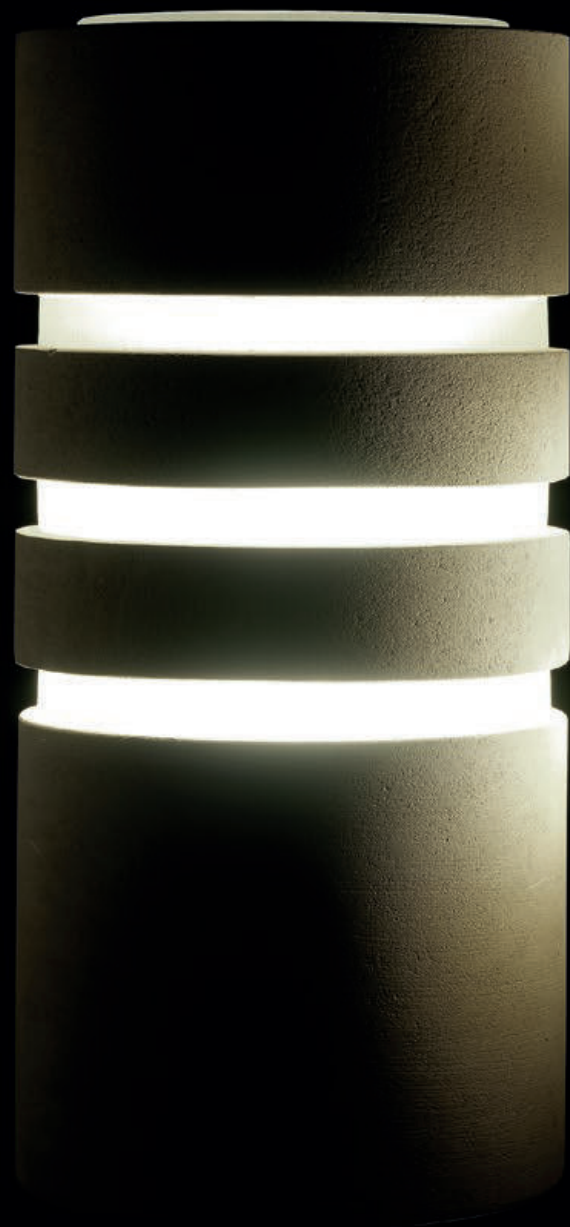



mezzanotte 300







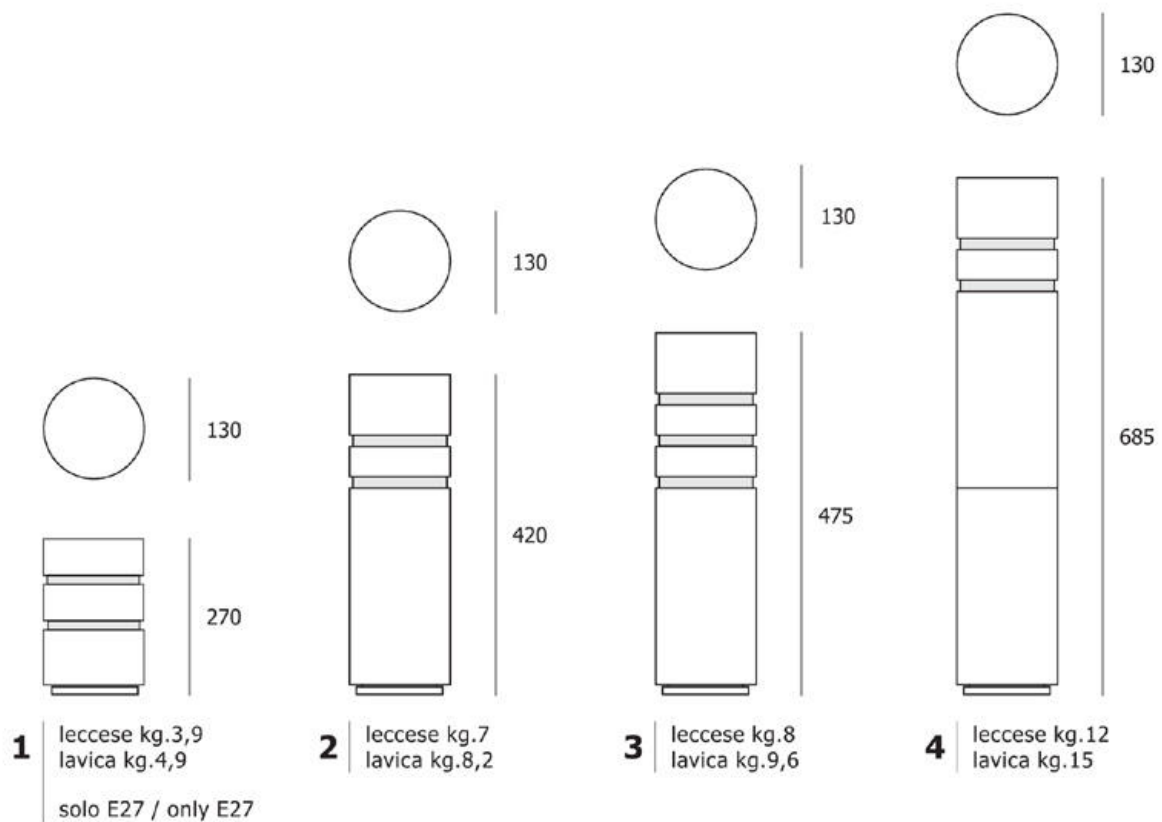

(per specifiche di ancoraggio a terra vedi pag.186 / go to page 186 for grounding/anchoring instructions)

1  
**11 501**

2  
**11 502**

3  
**11 503**

4  
**11 506**

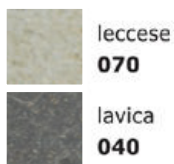

**001 - E27**

LED MAX 15W



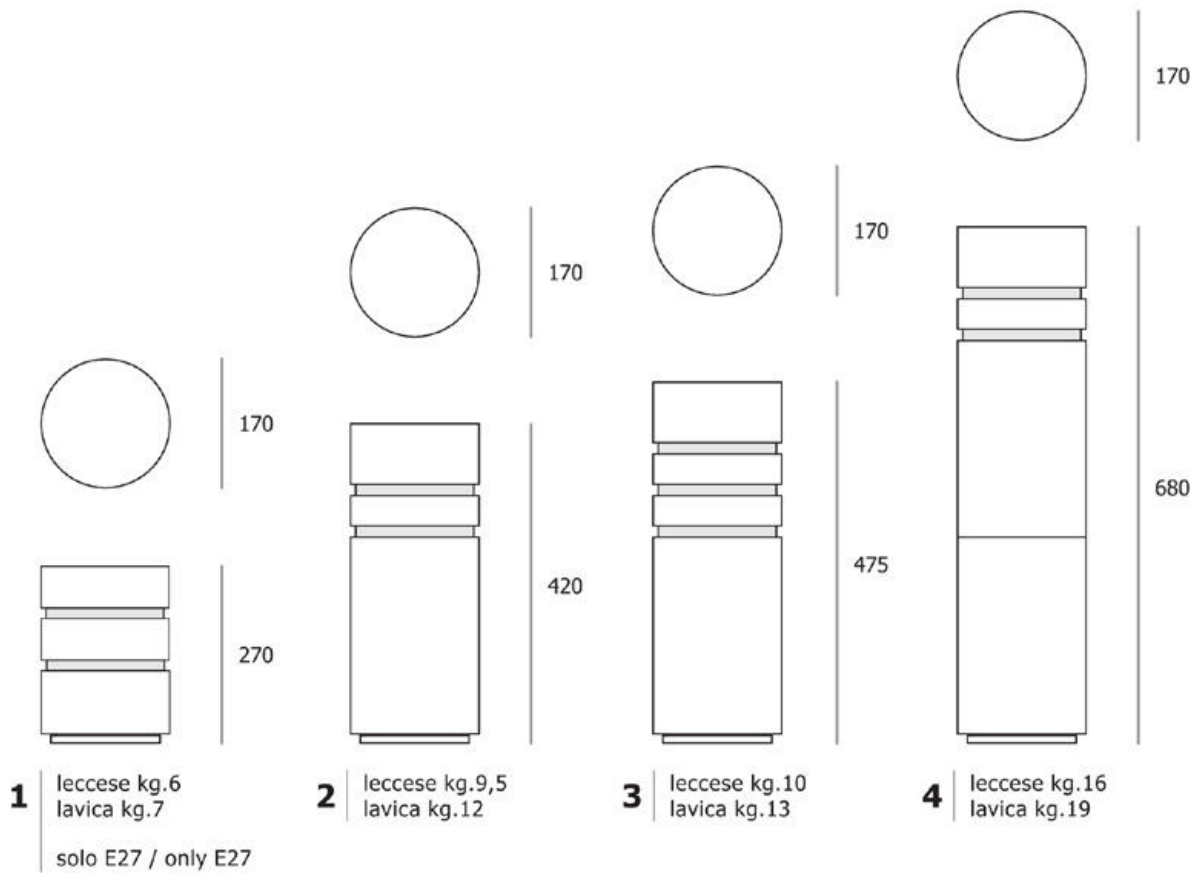

(per specifiche di ancoraggio a terra vedi pag.186 / go to page 186 for grounding/anchoring instructions)

1  
**11 701**

2  
**11 702**

3  
**11 703**

4  
**11 706**



**001** - E27

LED MAX 15W

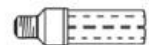



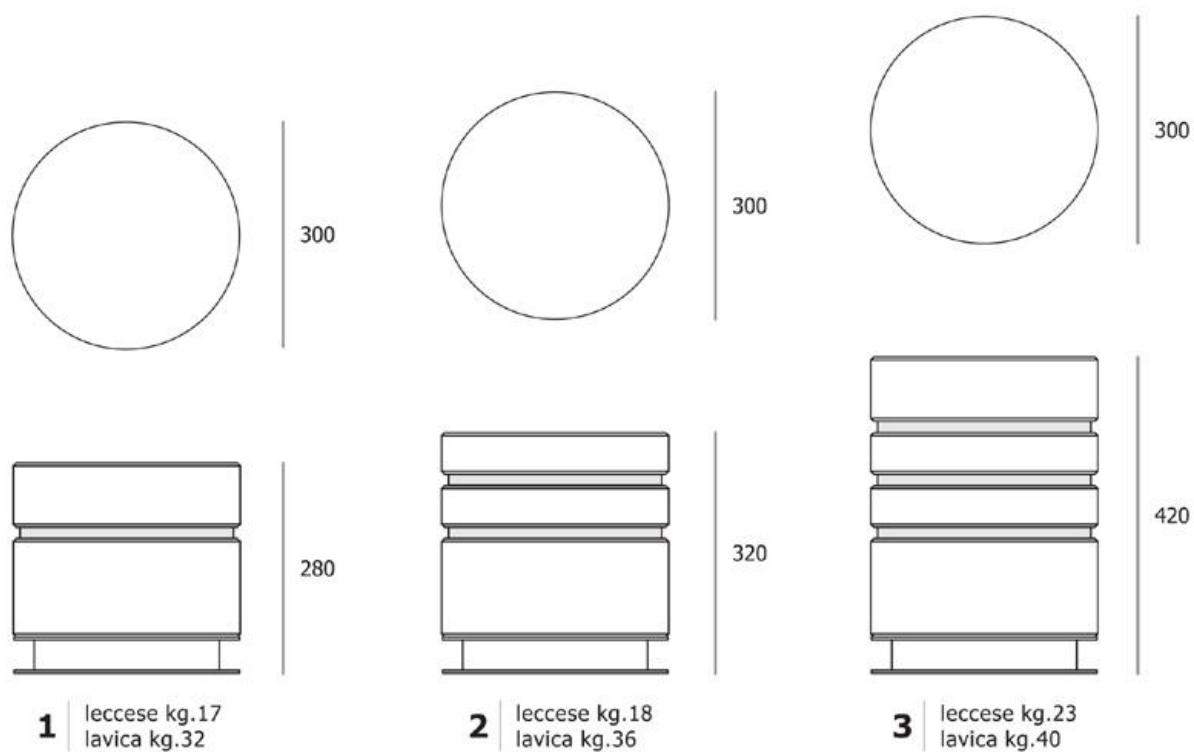

(per specifiche di ancoraggio a terra vedi pag.186 / go to page 186 for grounding/anchoring instructions)

- 1  
**11 901**
- 2  
**11 902**
- 3  
**11 903**

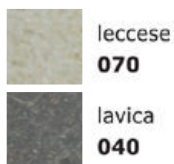

**001** - E27

LED MAX 15W

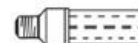

o m b r a

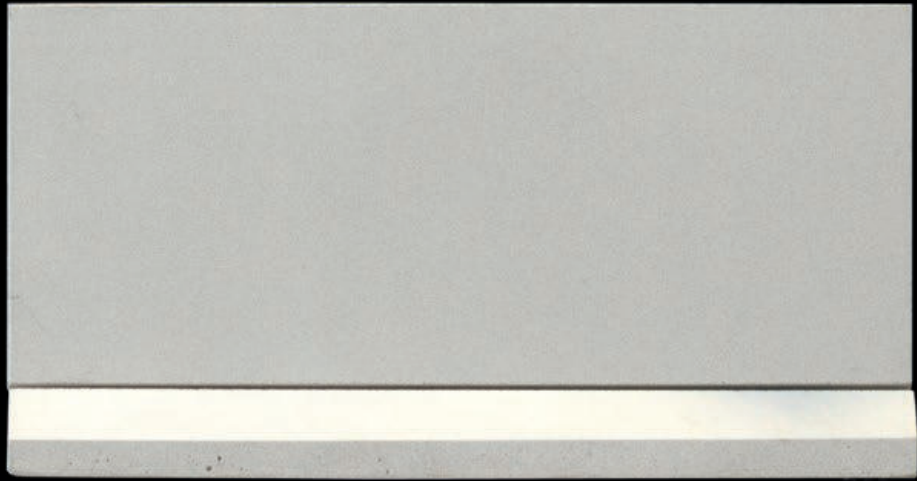

# ombra

Lampada da esterno concepita per essere a scomparsa.  
Realizzata in pietra crema, materiale dolce al tatto e quasi  
neutra nel colore, che all'occorrenza si presta anche ad essere  
tinteggiata per diventare un tutt'uno con il muro.

*Wall lamp for outdoor use designed to become one  
with the wall. Realised in Crema stone featuring a soft  
tactile impact and almost neutral colour it can  
be varnished for a perfect camouflage.*







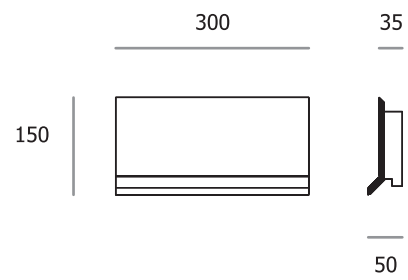

---

ombra

Kg. 4,3

**13 035**



crema  
**060**

**001** - LED

striscia led 3x1W  
led reglette 3x1W



pop maxi





## pop - pop maxi

Corpo lampada da parete per interni disponibile in tre materiali diversi, ardesia lucida, pietra crema e pietra serena, struttura in lamiera verniciata e diffusori in vetro sabbato. Due versioni disponibili; Pop e Pop Maxi.

*Wall lamp for indoor use proposed in shiny slate Stone, Crema Stone and Serena Stone, structure of varnished steel and diffusers of sandblasted glass, Two versions available; Pop and Pop Maxi.*

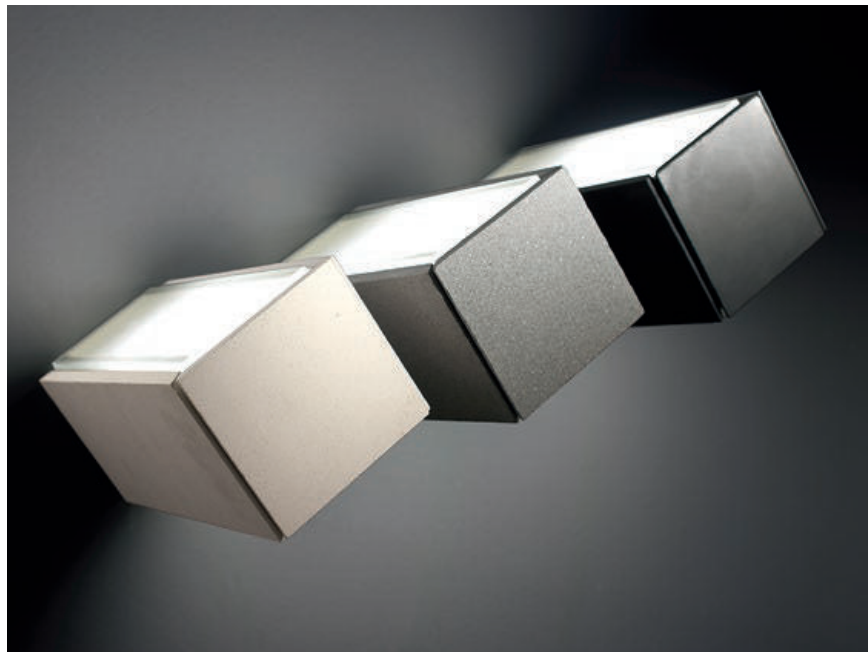







**16 001**

-  ardesia lucida **011**
-  serena **020**
-  crema **060**

**001 - E27**      LED MAX 12W



A  IP33  230V    

**16 002**

-  ardesia lucida **011**
-  serena **020**
-  crema **060**

**001 - E27**      LED MAX 2X12W



A  IP33  230V    





# block

Lampada da parete per interni ed esterni con grado di protezione IP55. La pietra, ricavata da concio, in questa linea è strutturale e conferisce alla lampada grande matericità e presenza. È prevista in sei varianti che soddisfano la vasta gamma di necessità illuminotecniche.

*Wall lamps for indoor and outdoor use with protection rating factor IP55; in this line of products the Lecce stone obtained from ashlar block is structural thus the material acquires great impact and presence. Six versions available, some with metal halide to address a wide range of illumination needs.*





b l o c k













block mini





block maxi





block orizzontale





block verticale



block

Kg. 3,5

**13 038**

-  leccese **070**
-  rosso mattone **071**
-  antracite **073**
-  marrone **074**

**001 - E27**      LED MAX 15W



A  IP55   230V    

block mini

Kg. 0,8

**13 036**

-  leccese **070**
-  rosso mattone **071**
-  antracite **073**
-  marrone **074**

**001 - G9**      LED MAX 6W



 IP55   230V    

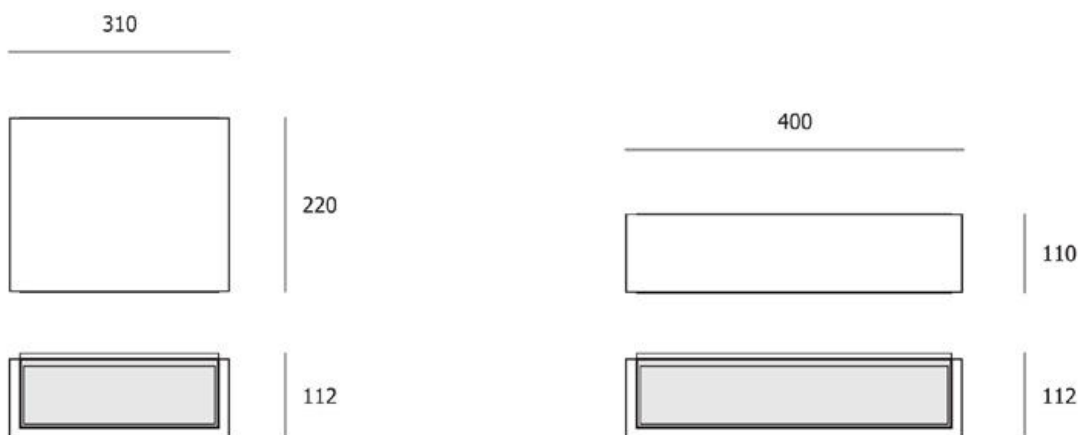

block maxi

Kg. 5,4

**13 037**

-  leccese **070**
-  rosso mattone **071**
-  antracite **073**
-  marrone **074**

**001 - E27**      LED MAX 2X12W



A  IP55   230V    

block 400

Kg. 4,2

**13 052**

-  leccese **070**
-  rosso mattone **071**
-  antracite **073**
-  marrone **074**

**001 - E27**      LED MAX 2X12W



 IP55   230V    



110



450



112

block plus

Kg. 6,4

13 041



leccese  
**070**



rosso mattone  
**071**



antracite  
**073**



marrone  
**074**

002 - GU10

LED MAX 7W

LAMPADINA DISPONIBILE A RICHIESTA  
LAMP BULB AVAILABLE ON DEMAND



# block orizzontale

# block verticale

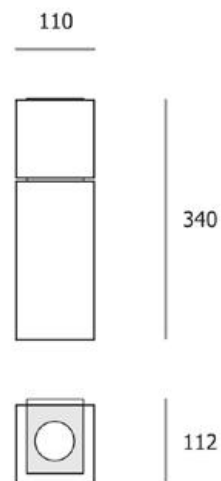
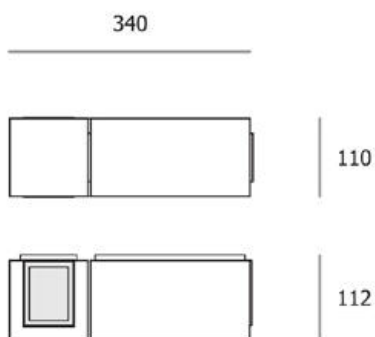

block orizzontale

Kg. 5

**13 040**

-  leccese **070**
-  rosso mattone **071**
-  antracite **073**
-  marrone **074**

**001 - G9**      LED MAX9W



A  IP55    230V    

block verticale

Kg. 4,6

**13 039**

-  leccese **070**
-  rosso mattone **071**
-  antracite **073**
-  marrone **074**

**002 - GU10**      LED MAX 7W

LAMPADINA DISPONIBILE A RICHIESTA  
LAMP BULB AVAILABLE ON DEMAND



A  IP55    230V    





cody

Lampada progettata per rendere protagonista la pietra che la costituisce. I diffusori abbassati dietro una vela di pietra, resa sottile da mani esperte nella sua lavorazione. . . . la materia senza il suo peso.

*Wall lamp designed to enhance the stone used. Its glass diffusers disappear behind a stone wing thinned down by the expert hands of our artisans...the impression, mater made weightless.*















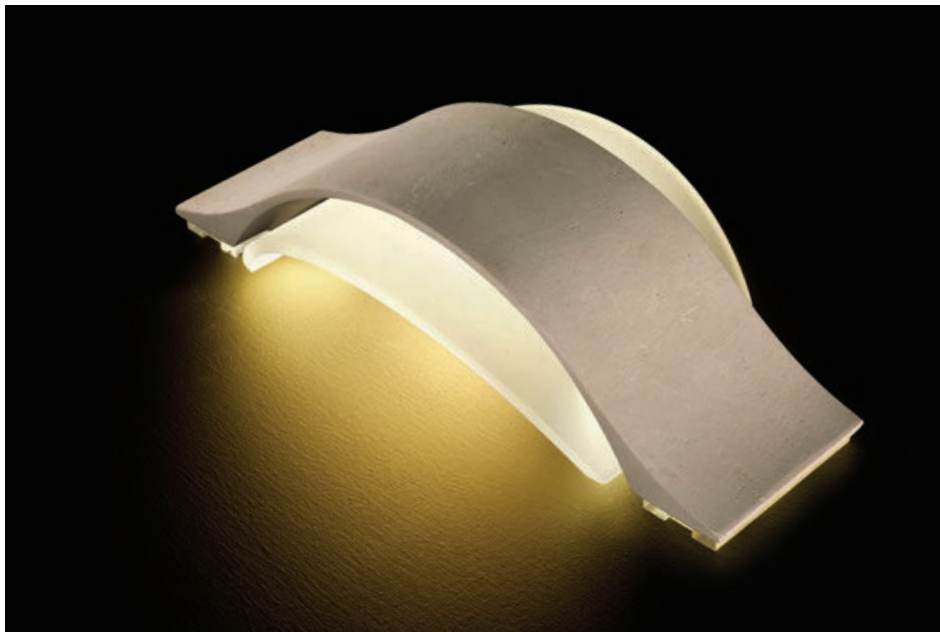
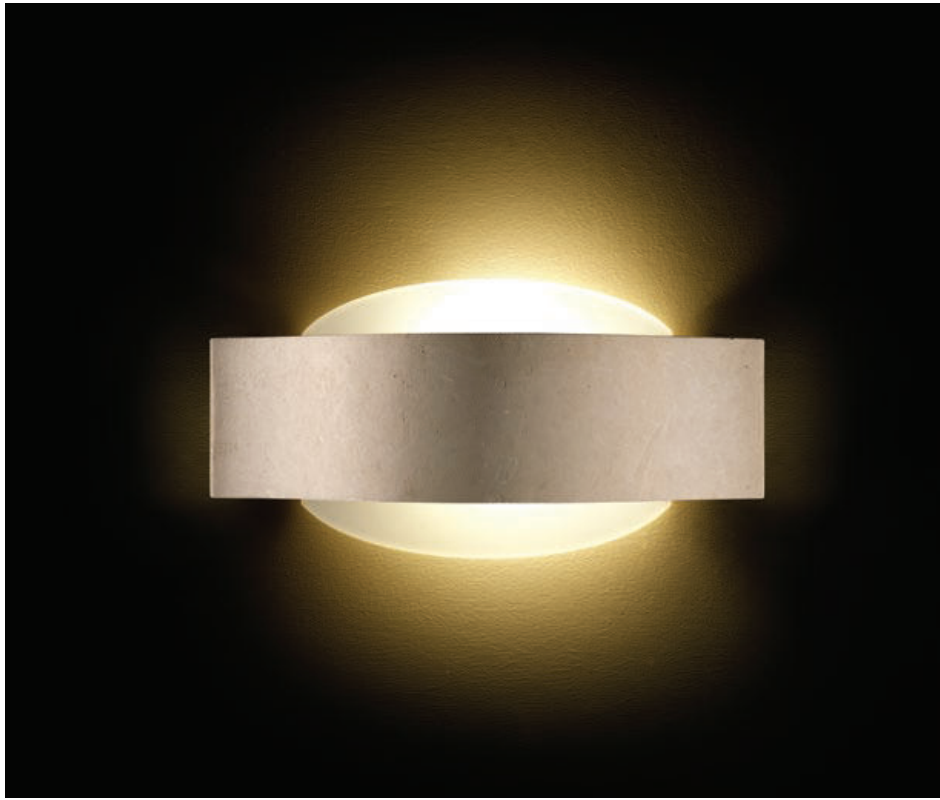

c o d y l i t e



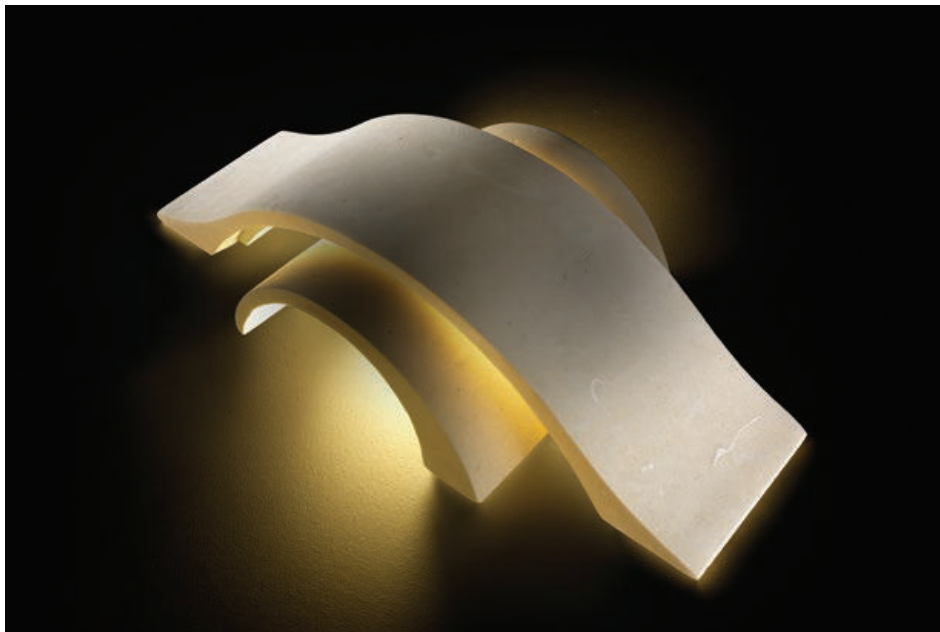



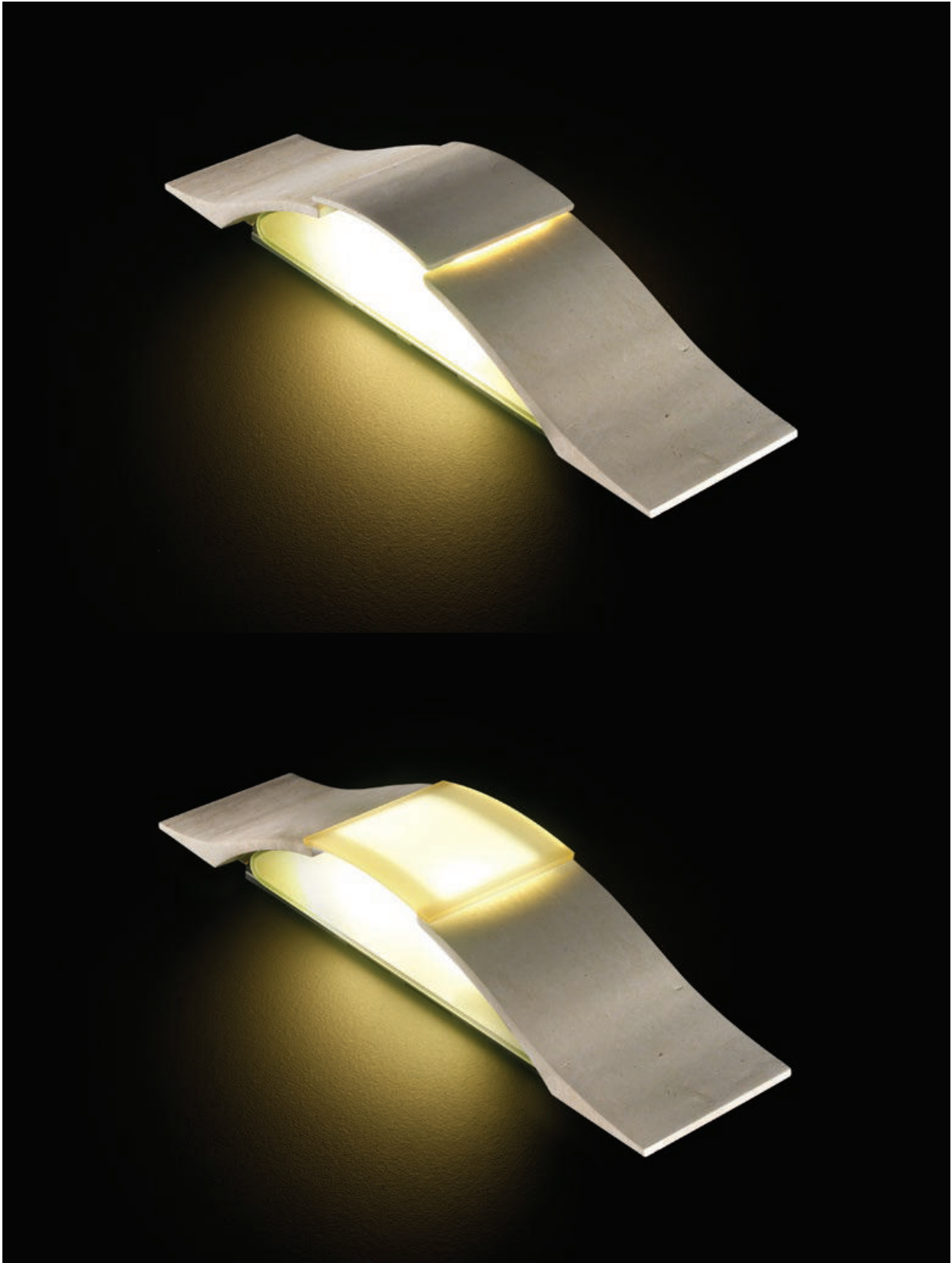



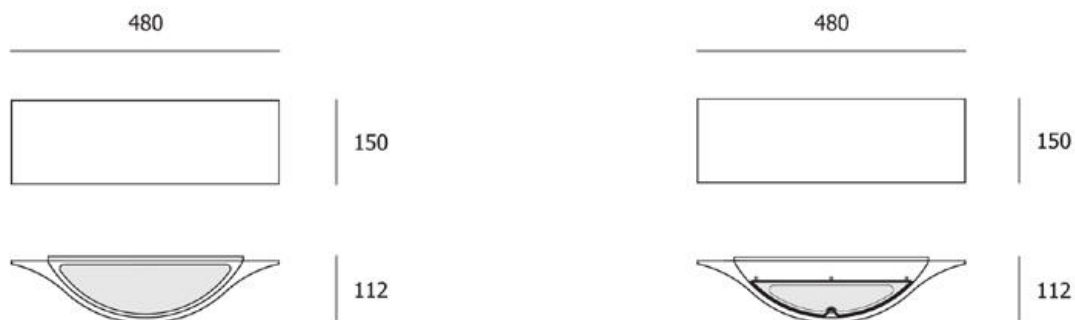

cody

Kg. 3

**13 045**

-  leccese **070**
-  rosso mattone **071**
-  antracite **073**
-  marrone **074**

**001** - E27      LED MAX 15W



A  IP55    230V    CE

cody JM

Kg. 3,5

**13 058**

-  leccese **070**
-  rosso mattone **071**
-  antracite **073**
-  marrone **074**

**001** - E27      LED MAX 15W



A  IP55    230V    CE

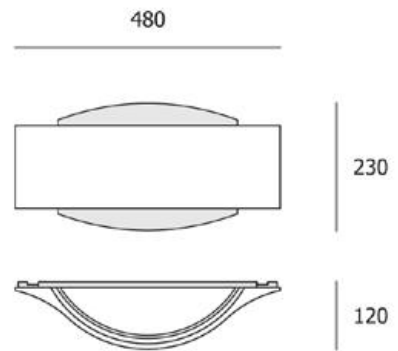
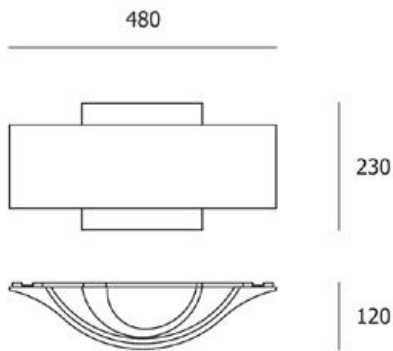

cody moma

Kg. 3,8

13 048



001 - E27

LED MAX 15W



cody lite

Kg. 5

13 049



001 - E27

LED MAX 15W

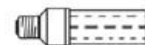

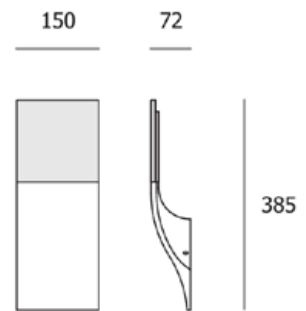

**13 043**



leccese  
**070**



rosso mattone  
**071**



antracite  
**073**



marrone  
**074**

**001** - E27

LED MAX 15W





corpo in pietra e metacrilato / stone and plexiglass body

corpo in pietra / stone body

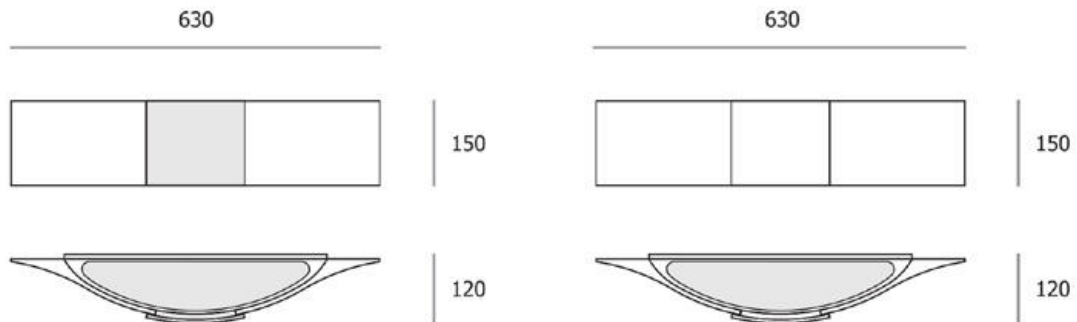

corpo in pietra e metacrilato / stone and plexiglass body

Kg. 3

13 050



001 - E27

LED MAX 2X12W

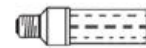

A IP55 230V

corpo in pietra / stone body

Kg. 3

13 060



001 - E27

LED MAX 2X12W



A IP55 230V



a f r a

# afra

Applique a doppia emissione, superiore ed inferiore, semplice ed elementare nelle forme, nell'installazione ed in tutto ciò che la caratterizza. Disponibile in due versioni, per uso interno ed esterno per consentire una maggiore versatilità di impieghi.

*Wall lamp with superior and inferior emission, almost elementary in its forms, simple to install and in each and every one of its characteristics. Available in two versions, indoor and outdoor, to allow for a greater variety of uses.*

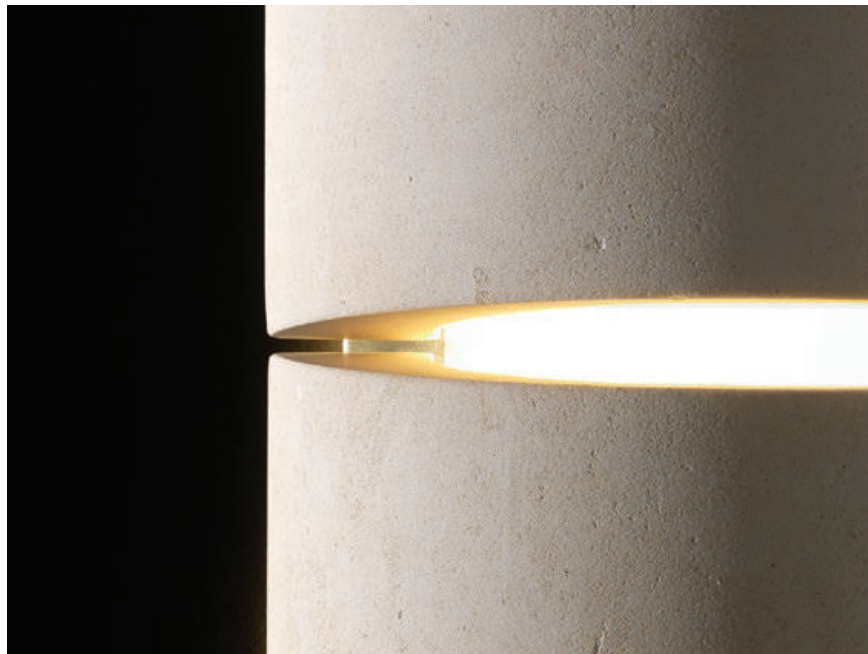





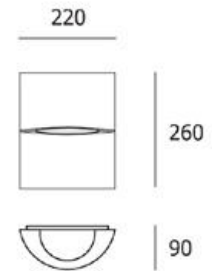
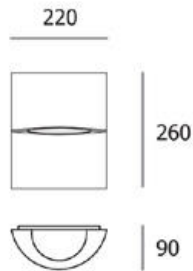

afra

Kg. 3,5

**13 047**

-  leccese **070**
-  rosso mattone **071**
-  antracite **073**
-  marrone **074**

**001** - E27      LED MAX 2x12W



 IP20  230V   

afra IP55

Kg. 3,7

**13 046**

-  leccese **070**
-  rosso mattone **071**
-  antracite **073**
-  marrone **074**

**001** - E27      LED MAX 2x12W



 IP55    230V    





## yoyo

Lampada da parete per esterni e interni dalle dimensioni importanti in pietra leccese, acciaio inox e diffusori in metacrilato. Prevista da parete e da soffitto.

*Wall lamp for outdoor use featuring important dimensions and made of; Lecce stone, stainless steel and with diffusers of Plexiglas. Ceiling versions available too.*





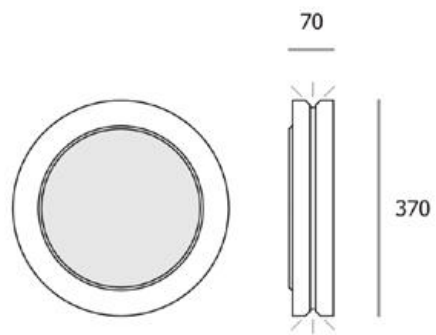

13 042



leccese  
**070**



rosso mattone  
**071**



antracite  
**073**



marrone  
**074**

001 - LED

CIRCULAR LED SUPERSLIM MAX 20W





# yoyo up

soffitto / ceiling

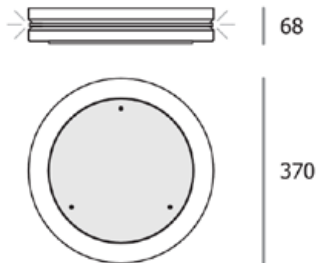

yoyo up

Kg. 5,2

12 042

-  leccese  
**070**
-  rosso mattone  
**071**
-  antracite  
**073**
-  marrone  
**074**

001 - LED

CIRCULAR LED SUPERSLIM MAX 20W



A  IP55    230V    



sole di mezzanotte

## sole di mezzanotte

Lampada da terra per esterni in pietra leccese con grado di protezione IP55 particolarmente adatta per illuminare giardini o parchi residenziali. Due le versioni disponibili in altezze diverse, Sole di mezzanotte e Piccolo sole.

*Floor lamp for outdoor use, made of Lecce stone, IP55 rating, perfect to illuminate gardens and residential parks. Two versions featuring different heights, Sole di Mezzanotte and Piccolo Sole.*

















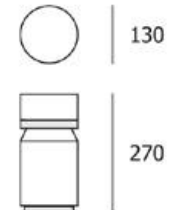
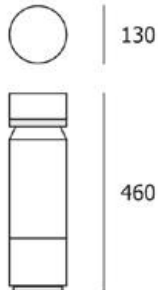

sole di mezzanotte (per specifiche di ancoraggio a terra vedi pag.186 / go to page 186 for grounding/anchoring instructions)

Kg. 7

11 022



002 - E27

LED MAX 15W

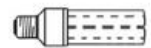

A IP55 230V CE

piccolo sole (per specifiche di ancoraggio a terra vedi pag.186 / go to page 186 for grounding/anchoring instructions)

Kg. 4

11 024

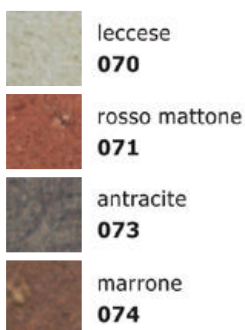

001 - E27















LED MAX 15W



IP55 230V CE



## simboli - symbols

	prodotto conforme alle direttive europee produced in compliance with EC directives	apparecchio adatto per il montaggio diretto su superfici normalmente infiammabili luminaries suitable for direct mounting on flammable surfaces	
	lampadina inclusa lamp bulb included	protezione contro corpi solidi IP 5x protection against solid object IP 5x	
	lampadina esclusa lamp bulb excluded	protezione da acqua IP x5 protection against water IP x5	
	classe 1 - non solo isolamento principale (involucro), anche con collegamento ad un conduttore di protezione. classe 1 - not only basic insulation (body), additional safety by means of connection to protective conductor.	sostituire gli schermi di protezione danneggiati replace any cracked protective shield	
		illuminazione da interni for internal use	
	classe 2 - non solo isolamento principale ma con doppio isolamento o isolamento rinforzato, non comporta dispositivi per la messa a terra. classe 2 - not only basic insulation but also with reinforced insulation, no provision for protective earthing.	illuminazione da esterni for outside use	
		alimentatore / trasformatore incluso power supplier / transformer included	
	cavo con interruttore a pedale e spina italia 10A inclusa cable with pedal switch and italia 10A plug included	alimentatore / trasformatore escluso power supplier / transformer excluded	

## grado di protezione - protection rating

<b>IP0X</b>	non protetto no protection	non protetto no protection	<b>IPX0</b>
<b>IP1X</b>	contro corpi estranei >50mm protection against solid object >50mm	protetto contro la caduta verticale di gocce d'acqua protected against water drops falling vertically	<b>IPX1</b>
<b>IP2X</b>	contro corpi estranei >12mm protection against solid object >12mm	protetto contro la caduta di gocce d'acqua inclinazione max 15° protected against water drops max inclination 15°	<b>IPX2</b>
<b>IP3X</b>	contro corpi estranei >2,5mm protection against solid object >2,5mm	protetto contro la caduta di gocce d'acqua inclinazione max 60° protected against water drops max inclination 60°	<b>IPX3</b>
<b>IP4X</b>	contro corpi estranei >1mm protection against solid object >1mm	protetto contro i getti d'acqua da tutte le direzioni protected against sprinkling water	<b>IPX4</b>
<b>IP5X</b>	protezione contro la polvere dust - protected	protetto contro gli spruzzi d'acqua da tutte le direzioni protected against water jets	<b>IPX5</b>
<b>IP6X</b>	protezione totale contro la polvere dust - protected	protetto contro le inondazioni protected against flooding	<b>IPX6</b>
		stagno all'immersione temporanea protected against brief immersions	<b>IPX7</b>
		stagno alla sommersione protected against immersions	<b>IPX8</b>



# istruzioni per effettuare l'ordine - to order

afra

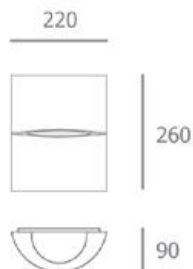

afra

Kg. 3,5

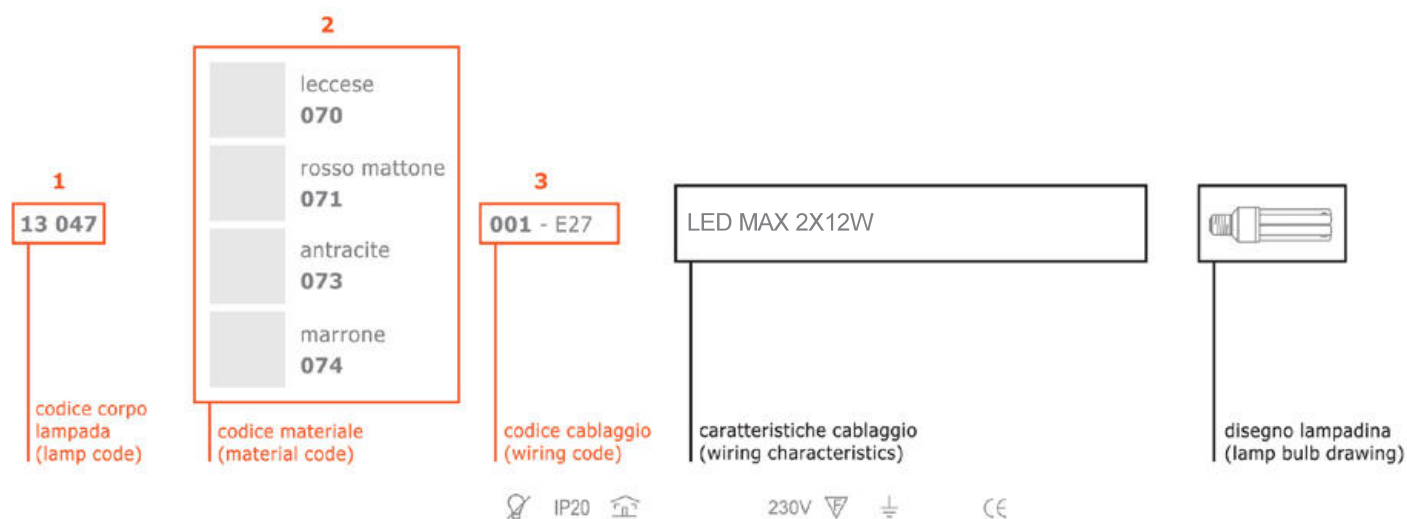

## genera il codice / generate the code

I nostri codici sono divisi in tre parti / Our codes are composed of three parts

1. codice corpo lampada / code of model
2. codice materiale / code of material
3. codice cablaggio / code of wiring

Esempio / Example:

Per ordinare la lampada AFRA in pietra "pigmentata" rosso mattone con cablaggio E27, dovremmo comporre il codice come segue:  
The code of our lamp AFRA of Lecce stone pigmented brick red and wired for E27 is:

**13 047 071 001**

## specifiche di ancoraggio - for grounding/anchoring instructions

Per motivi di sicurezza, e per proteggere la pietra da macchie dovute ad assorbimento di umidità e/o erba, tutte le lampade a terra devono essere isolate dal terreno ed installate su piazzola/plinto in cemento.

In ambienti climatici con temperature particolarmente rigide (es. ambienti alpini), raccomandiamo di scegliere pietre dure, siamo a completa disposizione per suggerire i materiali più idonei.

For safety reasons and to protect stone from humidity or grass stains, all floor lamps must be isolated from ground and installed on a thin cement layer.

We recommend choosing hard stones in areas having harsh winters (ex. Alpine regions), call us for assistance in choosing the most suitable materials.



Le richieste del Cliente sono da sempre al centro della nostra attenzione.

In venti anni di vita Ca' Belli ha sviluppato tutte le capacità necessarie per la realizzazione di progetti piccoli e grandi. La nostra produzione standard riesce a soddisfare la maggior parte delle esigenze, ma ci sono anche realizzazioni che hanno un carattere ed una connotazione talmente precisa da richiedere oggetti illuminanti creati ad hoc.

Spesso la richiesta nasce dal Cliente, altre volte è invece il Professionista ad interpellarci.

Assieme definiamo design, materiale, fonti luminose per arrivare alla creazione di un oggetto fatto su misura, perché "Creare è dare una forma al proprio destino" (Albert Camus).

Clients' requests have always been our main focus. In the twenty-year period since its birth date, Ca'Belli has gained a unique know-how based on design and materials and abilities enabling us to start from an innovative concept and obtain objects that can be introduced in projects of varying dimensions.

Our standard production can satisfy most needs but there are projects that have characteristics that are so peculiar that they need specially designed luminaries.

These special requests often come from clients, sometimes it is the planner or Architect instead to call on us. Together we define design, material and light sources and create an object made on demand because "Creating means to give shape to ones' own destiny"(Albert Camus).



## materiali - materials

Per l'azienda dare la propria disponibilità significa mettere a disposizione del Cliente la profonda conoscenza dei materiali naturali, caratteristica che appartiene in primis a Ca' Belli nel mondo dell'illuminazione. La gamma dei materiali a disposizione è variegata ed è limitata soltanto dalla disponibilità della natura. I materiali qui illustrati rappresentano una parte minima delle possibilità di utilizzo.

For Ca'Belli being helpful means first of all to offer its thorough knowledge of materials, a distinctive trait of Ca 'Belli alone in the lighting business, making it immediately available for the Client. The range of materials is multifaceted the only limit being the ones imposed by Mother Nature itself. The materials illustrated here represent only a minimal part of many possible applications.

## prodotti speciali - customized product

La flessibilità produttiva dell'azienda è in grado di soddisfare esigenze legate sia al residenziale che al contract. In questo caso Ca' Belli affianca lo Studio di progettazione per tutti i corpi illuminanti necessari, realizza i prototipi funzionanti e dà seguito alla produzione richiesta.

I prodotti fotografati rappresentano solo una parte dei vari progetti-custom nati da richieste specifiche della Clientela.

Our flexibility in terms of production enables us to satisfy the needs of clients both in the residential and in the contract sectors. For contract jobs, Ca 'Belli works side by side with the light planning Studios to design the items requested, we then produce the prototypes and finally deliver the requested product. The products illustrated in this page represent a small part of the many customized projects made on demand according to Clients specifications.

