

VISION SYSTEM

TUNNEL LIGHTING



Modularity
Thermally optimized
Diverse optic
Fast installation
Easy maintenance
Longevity



BUCK GmbH
Hietzinger Kai 67-69, 1130 Wien
Büroadresse: Fleischmarkt 1 | 6. Stock |
1010 Wien | Österreich
office@bucklicht.at
www.bucklicht.at

Copyright © 2023 BUCK, edition 3

BUCK
www.buck.lighting



TUNNEL LIGHTING

While driving through tunnel, lighting is all about your priceless safety.

VISION SYSTEM is an innovative, smart, all-inclusive tunnel lighting system designed to improve traffic safety and comfort standards through its high quality and energy efficiency. The high-level modularity design is realised via various optics, power and controllability options, which broadens its field of application to different tunnel types.



ENERGY EFFICIENCY

LED tunnel luminaire of high energy efficiency. Modularity, choice of different lenses and different nominal powers enable continuous adjustment of power from 54W to 646W and flux adjustment from 7 450 lm to 89 401 lm. Lighting management and communication for smart energy consumption.



Ambient temperatures up to 55°C

By choosing appropriate lighting distribution, depending on height of a tunnel and distance between luminaires, there are significant reductions in required installed power (compared to standard light sources).

Considering longevity of all components (>100,000h), the need for maintenance is reduced, leading to additional savings.

OPEN DESIGN

The open design concept enables the use of LEDs to their full potential. The power of the luminaire is determined by the number of installed LED modules. Each luminaire module consists of a compact heatsink with vertical ribs.

Experience in designing and producing open-design luminaires confirmed the reliability and durability of such luminaires in extreme outdoor conditions, such as high humidity, high temperatures, and big temperature oscillations, as in desert conditions.

THERMAL MANAGEMENT

The special heatsink design promotes excellent thermal dissipation resulting in a high longevity of LED modules.

The control gear compartment and light modules are separated, preventing heat transfer to the gear, and ensuring the longevity and reliability of the luminaire.



MODULARITY

This approach enables the usage of only one family of luminaires for the illumination and lumination of the whole range of different types of roads in the tunnels, regardless of the speed limit, traffic volume, composition, dimension of the tunnel and their longevity, etc. This gives us an opportunity to uniform tunnel luminaires in all types of tunnels, in city areas, and on highways.

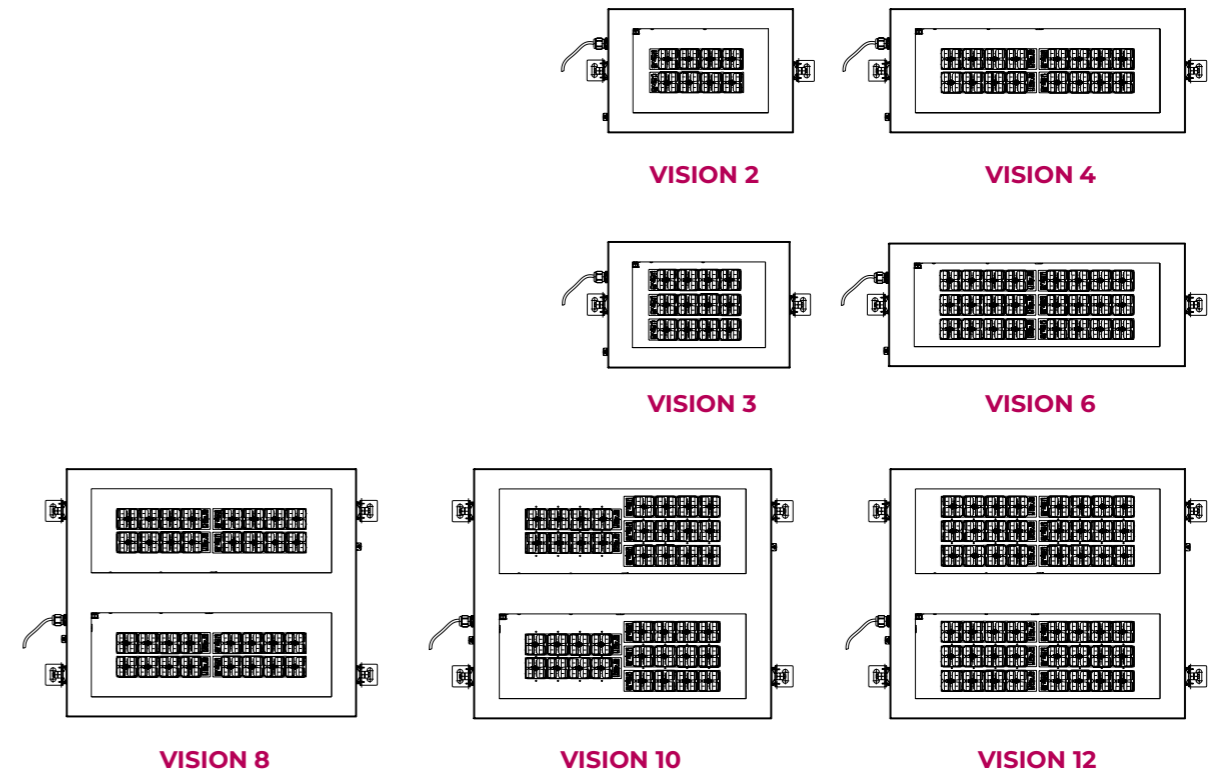

	DIMENSIONS A / B / H (mm)	LED LUMEN (4000/CRI 70/MAX) SYM / ASY	TOTAL POWER W MAX	WEIGHT kg
VISION 2	440 / 296 / 60	14900 / -	108	6.70
VISION 3	440 / 296 / 60	22350 / 19164	161	6.70
VISION 4	690 / 296 / 60	29800 / 25551	215	9.00
VISION 6	690 / 296 / 60	44701 / 37860	323	9.50
VISION 8	690 / 591 / 60	59601 / 50480	430	16.00
VISION 10	690 / 591 / 60	74501 / 63100	538	16.20
VISION 12	690 / 591 / 60	89401 / 75719	646	16.50

OPTICS

PMMA lenses of high light transmission (90%) and a tempered, 5mm thick glass protector. A vast range of different powers and lenses cater to wide applications in all types of outdoor illumination.

The distribution of light is defined by lenses made of optical grade PMMA with high UV and temperature resistance, appropriate for high current and temperature conditions. These lenses allow better targeting of light rays so that light pollution and scattering to adjacent walls are minimized. The lighting requirements that may occur in different tunnel sections, or in outdoor spaces such as galleries, underpasses, pedestrian zones, accessible cross- passages, parking areas, and approach roads / ramps and roundabouts / intersections can be met by choosing standardized lenses with appropriate light distribution.

Optics efficiently prevent the light above the horizontal surface of the luminaire (ULOR=0), eliminating light pollution.
4 standardized optics and an additional available on request.

11460 lm
to
89401

PMM LENSES
90 % LOR



OPTIC TYPES

STANDARD OPTIC

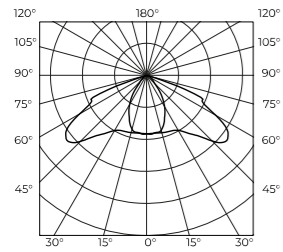

CAT-B

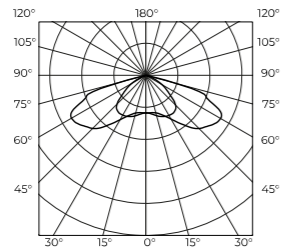

CAT

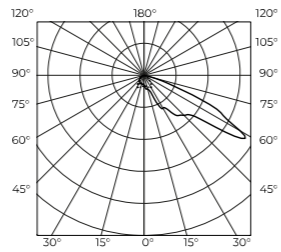

FT60

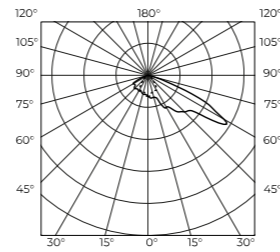

FT60 & CAT-B

OPTIC TYPES ON REQUEST

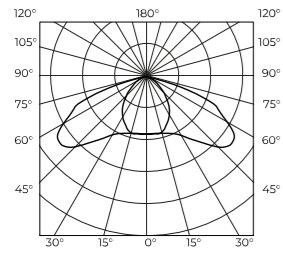

CAT-B & CAT

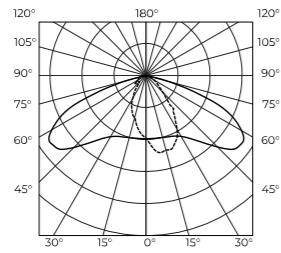

CAT-B & T2

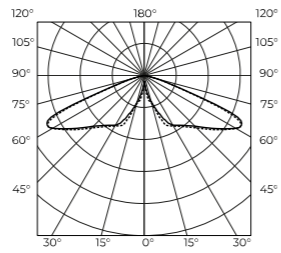

VSM

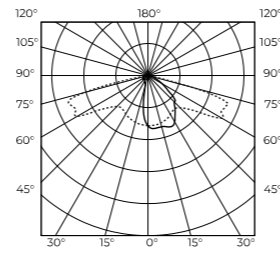

DWC

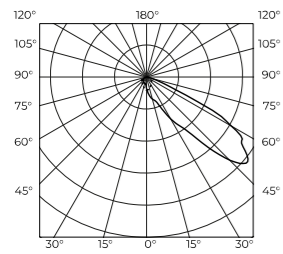

TF & FT6

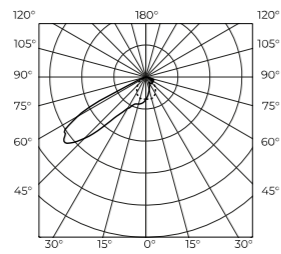

FN & FT6

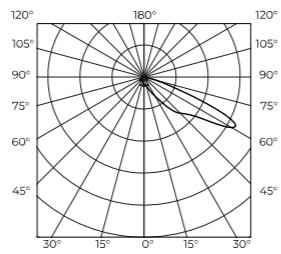

FS3

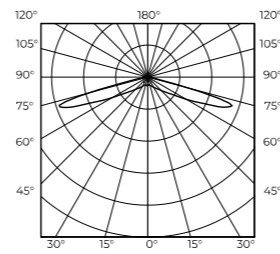

T1

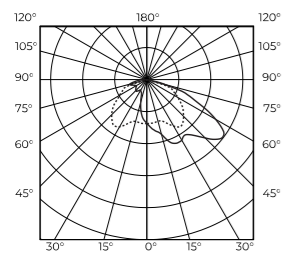

T4

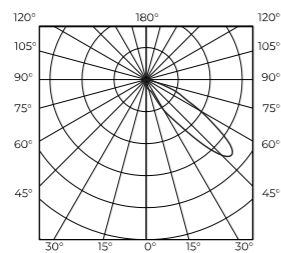

TF

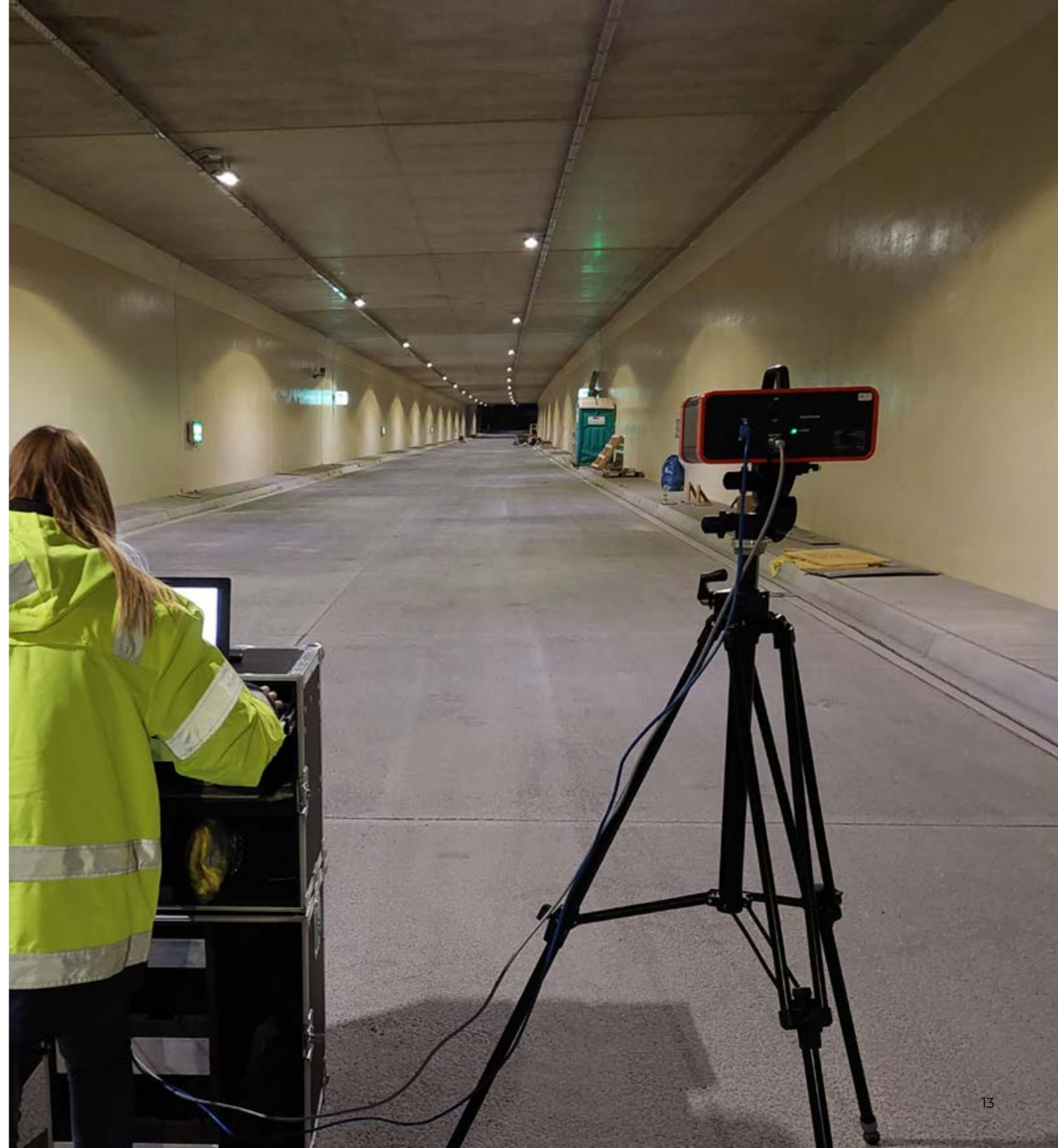

TECHNICAL DATA

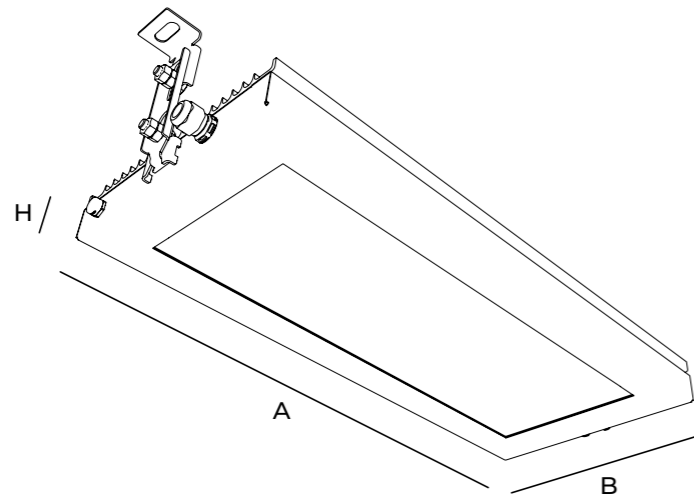

Dimensions A / B / H	440/296/60, 690/296/60
Ingress protection rating	IP66 on 6 bar
Impact resistance rating	IK08 / IK09
Finish	Electropolished stainless steel
Weight	6.7 - 12.5 kg
Ambient temperature range	≤40°C , HT ≤55°C
LED service life	> 100.000h (L90B10)
Lens LOR	> 90%
Luminaire luminous flux	11460- 8940lm
Total power	108 - 646W
Luminaire efficiency	> 122lm/W
Luminaire LOR	ASY > 81%, SYM > 84%
Light colour temperatur / CRI	3000K-5700K / 70-80
Power supply	220- 240V 50/60Hz
Constant current range	350- 1050mECC
Control gear	ECC, DIMM 1-10, DSI, DALI, 4-20mA, Line Switch

The housing of the luminaire is made of stainless steel EN 1. 4571 (AISI 316 Ti), protected by epoxy polyester powder coating of fine structured texture or electrochemically polished and passivated for highest resistance to corrosion.

Heatsink body is made of extruded aluminum alloy treated with conversion protection and physically separated from stainless steel housing to avoid galvanic corrosion.

Sealed luminaire is protected against ingress of dust and moisture, as well as solution jets of tunnel washing machines to provide complete reliable usage. Corrosion proof, impact resistant, and optimal thermal management assured long-lasting function.





JUNCTION BOX

Complete control gear is mounted on a carrier in JunctionBox which can easily be replaced on-site.

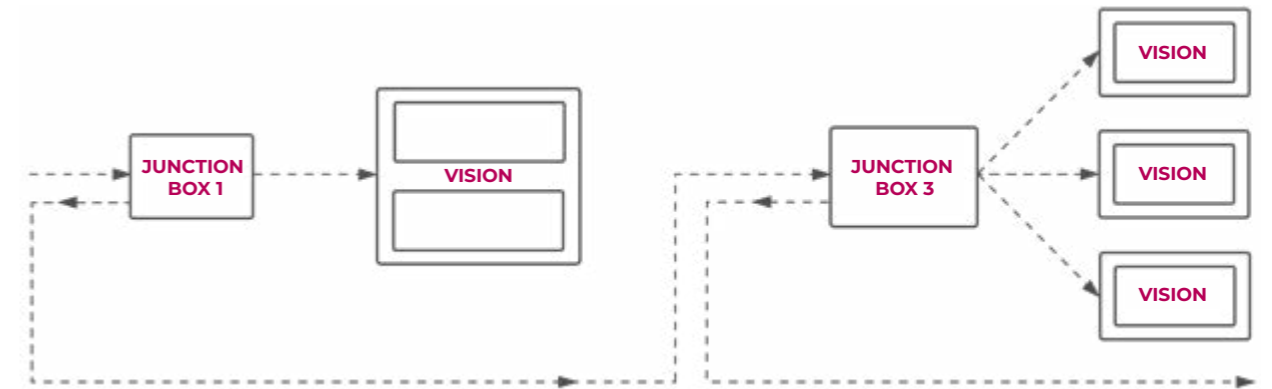
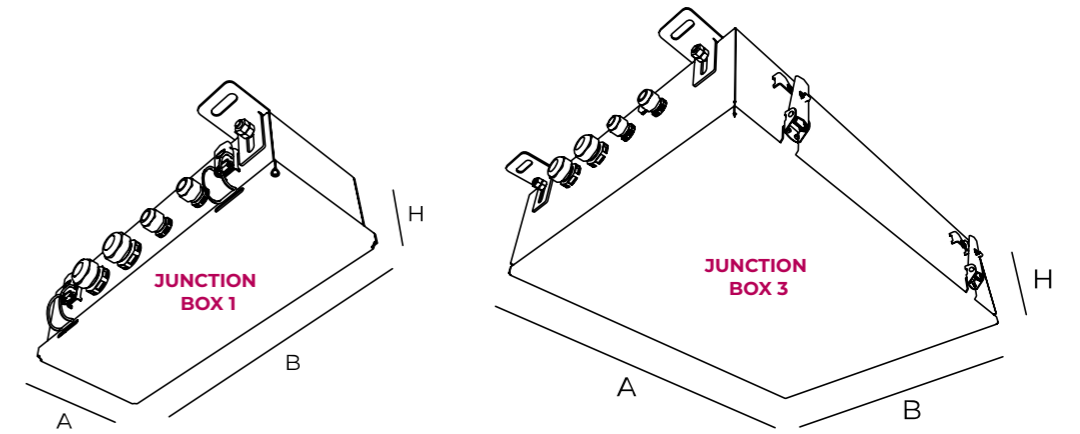

	DIMENSIONS A / B / H (mm)	LED DRIVER MAX	TOTAL POWER W MAX	WEIGHT kg
JUNCTION BOX 1	164 / 415 / 130	2	400	6.50
JUNCTION BOX 3	690 / 500 / 173	6	1200	22.00

STANDARD EQUIPMENT

- Wireless interface communication
- Programmable
- AOC - Adjustable Output Current
- CLO - Constant light output
- Virtual midnight
- Protection against transient main peaks up to 6 kV
- Electronic short-circuit protection
- Overload protection
- Thermal protection
- Voltage range 198-264VAC
- Safety switch
- 1-10V analogue management
- JB 3
- 1m cable from luminaire

ADDITIONAL EQUIPMENT AND/OR POSSIBILITIES

- Powder coating stainless steel
- Central management
- Protection against transient main peaks up to 10 kV
- Voltage range 150-264VAC
- DALI communication
- CLi [4-20mA- analog control]
- SDi [230V- discrete control]
- JB 1
- Click connectors
- Screw connectors
- Mounting brackets of 1.4529 – steel
- Programmable directly at the mounting site via wireless interface communicator.

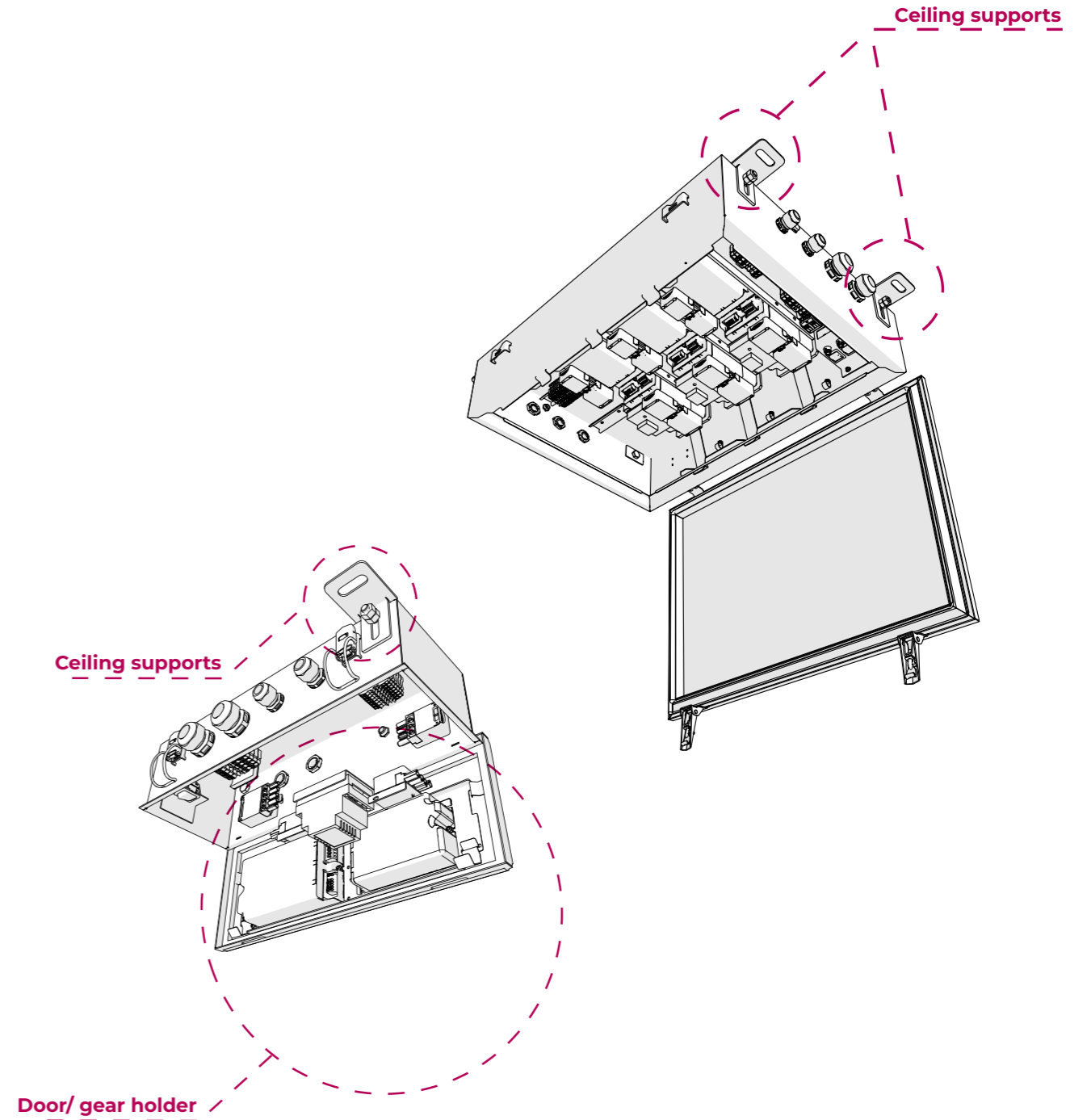

**ACCESS TO
ELECTRICAL COMPONENTS
WITHOUT TOOLS**



**SIMPLE
UPGRADE**



SERVICEABILITY

The safety brackets of the electric component can be removed with the help of the installed spring, without tools.
LED modules are serviced using standard tools.

Possibility to perform maintenance by merely replacing the carrier with spare one, using quick connectors, without interruption in illumination level or operating of the whole lighting installation.



**EASY
ACCESS**





MOUNTING

Optimized for quick mounting and maintenance.

Considering longevity of all applied components (MTBF >100,000h), the need for maintenance is reduced, almost none, leading to additional savings and long periods of planned preventive servicing.

Our luminaires are suitable for tunnel washing with automated cleaning vehicles.

Mounting directly on the ceiling/ wall or C-shine.



VISION 1-6

Luminaire with two brackets and the possibility of an angle adjustment of $\pm 45^\circ$.

VISION 8-12

Luminaire with 4 brackets and the possibility of an angle adjustment of $5,5^\circ$, on additional request with two brackets and an angle adjustment of $\pm 45^\circ$.

SIMPLE AND COST EFFICIENT SOLUTION

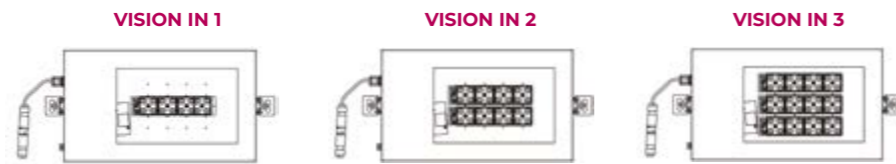

	DIMENSIONS A / B / H (mm)	LED LUMEN 4000K SYM / ASY	TOTAL POWER W MAX	WEIGHT kg
VISION IN 1	569 / 296 / 60	7450 / -	54	8.00
VISION IN 2	569 / 296 / 60	14900 / -	108	8.50
VISION IN 3	569 / 296 / 60	22350 / 19164	161	9.50

VISION IN

Our VISION family is richer for one more product, with integrated electrical components in the lamp itself.

Vision is designed with a special attention to the influence of traffic pollution and corrosion as well as wet conditions to enable proper electronic longevity.



SOLUTION WITH HIGH AMBIENT TEMPERATURES $T_a \leq 55^\circ\text{C}$

LED LUMINAIRE DESIGN FOR THE FUTURE

The quality of materials and protection covers is chosen to withstand exposure to the harsh tunnel environment.

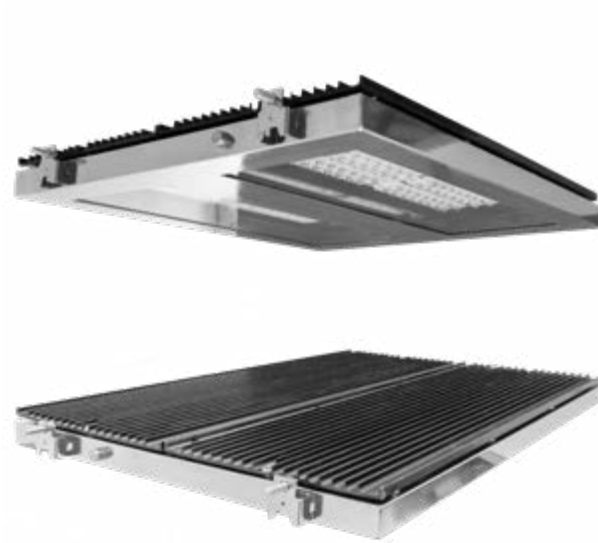

	DIMENSIONS A / B / H (mm)	LED LUMEN 4000K/CRI 70/ MAX SYM / ASY	TOTAL POWER W MAX	WEIGHT kg
VISION HT IN 2	569 / 296 / 60	13601 / -	96	9.00
VISION HT IN 3	569 / 296 / 60	17411 / -	120	9.00
VISION HT 4	690 / 296 / 60	23215 / -	160	9.00
VISION HT 6	690 / 296 / 60	- / 23936	173	9.50
VISION HT 8	690 / 591 / 60	- / 40370	311	16.00
VISION HT 10	690 / 591 / 60	- / 45036	339	9.00
VISION HT 12	690 / 591 / 60	- / 47288	346	16.50

BUCK TCC : TUNNEL COMPLETE CONTROL SYSTEM

SCADA
central system for real-time monitoring and control of regional traffic tunnels



TCA : Tunnel Control Agregator

Industrial PC for aggregating control over complete tunnel and execution of emergency scenarios due to incidents, e.g., fire, CO levels, traffic accident, SOS phone, power failure...



Industrial Hi-Speed Ethernet Optical Network
for connecting tunnels with regional command center



Industrial network
for tunnel equipment



TLC : Tunnel Local Control

Industrial PLC with communication interfaces for local control and execution in the tunnel section

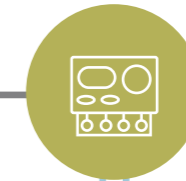

L20



Lighting control interface:

- RSi as digital bidirectional RS-485 interface (addressable luminaires with feedback);
 - SDi as discrete time coded 230 V step dim interface (no feedback);
 - CLi as analogue current loop 4-20 mA interface (no feedback).
- L20, Lth, Lin: Luminance meters as lighting control feedback.

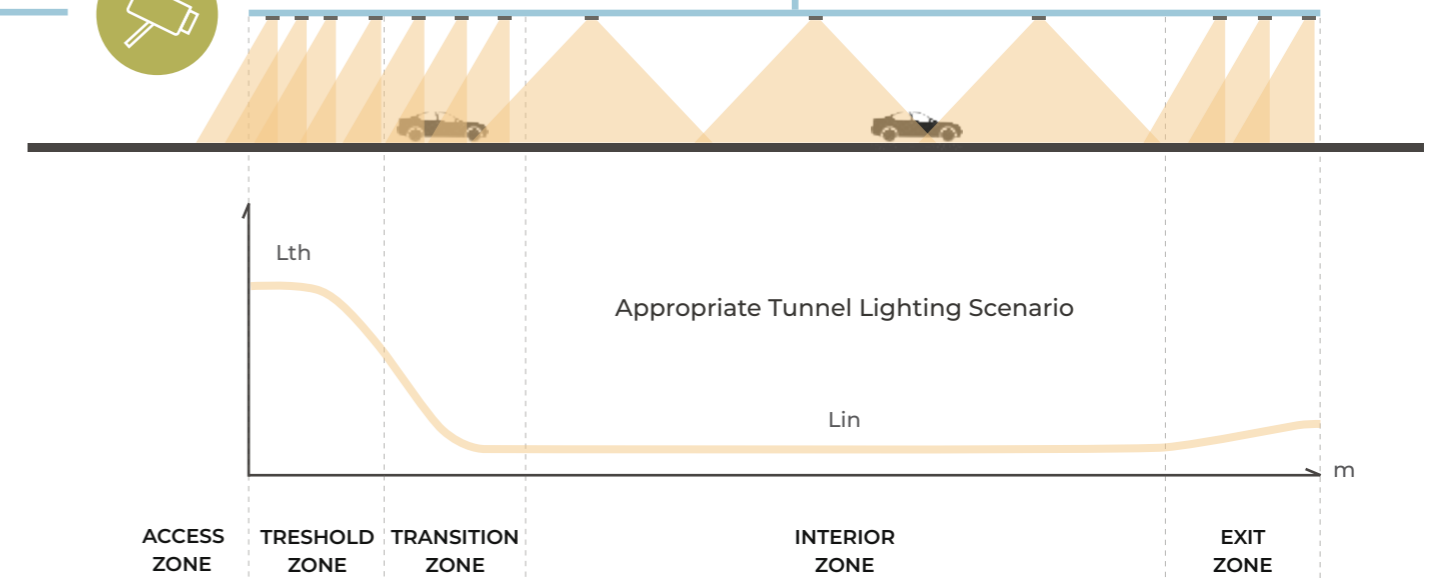



ALTERNATIVE ENERGY SOURCES

Installing solar panels or other types of renewable energy sources is an excellent way to take advantage of the benefits of “free” electricity while simultaneously reducing our dependence on the power grid.

This approach can decrease costs and alleviate the pressure on the network, particularly during peak usage throughout the day.

Additionally, renewable energy sources offer an almost infinite supply of energy from natural sources, and they are considered environmentally friendly because they generate little to no emissions of CO₂ and other harmful greenhouse gases that can damage the ozone layer or adversely impact the environment.

